

**CASK BOOK
FOR
MODEL CNS 8-120A**

EnergySolutions
Suite 100, Center Point II
100 Center Point Circle
Columbia, South Carolina 29210
Phone: 803.256.0450

Table Of Contents

- I. ER-99-018, Rev. 4, Conformance of CNS 8-120A Cask with Specifications for DOT 7A, Type A Packagings |
- II. Technical 3002, Rev.8, Cask Handling Procedure For US DOT Specification 7A, Type A Transportation Cask
- III. Drawings: |
- Drawing No. 29008-1, Rev. 6, Sheets 1 and 2 |
- IV. ER-99-023, Rev. 5, Conformance of CNS 8-120A Cask with Specifications for Industrial Packaging Type 1 and Type 2 |



Duratek™

140 Stoneridge Drive
Columbia, South Carolina 29210
803-256-0450
www.duratekinc.com

TO: CASK MANUAL HOLDERS

FROM: DURATEK, INC.

SUBJECT: REQUIRED DOCUMENTATION FOR INDUSTRIAL PACKAGINGS AND AUTHORIZED TYPE A PACKAGES

DATE: SEPTEMBER 8, 2004

Duratek's Cask Manuals include the cask handling procedures and drawings as well as documentation that address compliance for the respective cask to each of the requirements for IP or DOT Specification 7A containers, as appropriate. This documentation is in the form of an Engineering Report that includes reference to the respective cask's Safety Analysis Report (SAR). The SAR was previously prepared to demonstrate compliance with the requirements of 10 CFR 71. Duratek has maintained these SAR's "on-file" as controlled documents, which could be provided to the Offeror on demand at any time. However, this does not meet the requirements of 49 CFR. Specifically:

- 49 CFR 173.411(c) requires that:
Except for IP-1 packages, each offeror of an industrial package must maintain on file for at least one year after the latest shipment, and shall provide to the Associate Administrator on request, complete documentation of tests and an engineering evaluation or comparative data showing that the construction methods, packaging design, and materials of construction comply with that specification.
- 49 CFR 173.415(a) requires that:
Each offeror of a Specification 7A package must maintain on file for at least one year after the latest shipment, and shall provide to DOT on request, complete documentation of tests and an engineering evaluation or comparative data showing that the construction methods, packaging design, and materials of construction comply with that specification.

To assure compliance with the requirements of 49 CFR 173.411(c) and 49 CFR 173.415(a) pertaining to documentation "on-file", Duratek has made a down loadable copy of the complete SAR available for this cask on its Internet web page, www.Duratekinc.com (look under Client News). The document is in a pdf file format and can be maintained electronically or printed out, as desired.

If you have any questions or have problems down loading the document, please contact Duratek's Document Control Department (803-758-1844 / acgossett@duratekinc.com).



CHEM-NUCLEAR SYSTEMS, INC.

140 Stoneridge Drive • Columbia, South Carolina 29210 • (803) 256-0450

March 30, 1999
579-028-99

Dear Customer:

Effective April 1, 1999, Chem-Nuclear Systems' (Chem-Nuclear) packagings used for the transport of Type A, Low Specific Activity (LSA), or Surface Contaminated Object (SCO) materials are being regulated solely in accordance with Department of Transportation (DOT) criteria. These criteria pertain to unshielded payload configurations emitting less than or equal to 1 rem/hour at 3 meters. After this date, the Chem-Nuclear owned/operated casks, tabulated below, will no longer be licensed or regulated by the Nuclear Regulatory Commission as Type A LSA packagings.

The Chem-Nuclear fleet of casks affected by this regulatory change is as follows:

<u>CASK MODEL</u>	
CNS 6-75	CNS 14-190-H
CNS 6-80-2 / CNS 6-80-2A	CNS 14-195-H
CNS 8-120A	CNS 14-215-H Series A
CNS 14-170 Series II	CNS 21-300
CNS 14-170 Series III	TV-83 (LL-60-150)

In accordance with DOT regulations, shippers using DOT-regulated packagings must certify the package at the time of shipment as meeting the applicable requirements (e.g. 49CFR173.411(b)(2) for IP-II, or 49CFR173.415(a) for 7A), and must retain the documentation of this certification for at least one year after completion of the shipment. Chem-Nuclear has prepared the necessary qualification documentation for these casks, as well as updated the cask operating procedures to reflect the noted change in regulatory control. These documents are being provided for your information and use. (Please note that the IP-II qualification documentation will be transmitted under separate cover.)

As a reminder you, as shippers, are responsible for and must comply with all associated DOT regulations. The enclosed documents only reflect the qualification of the packaging for its intended use and additional shipper prepared documentation will be necessary for qualifying the package for shipment (the packaging with its contents).

This information is being transmitted in the form of change pages to the appropriate Cask Book for each packaging previously provided to you. To facilitate incorporation of this information into your Cask Book, a Revision Guide Sheet is included to assist you in the update process. We trust that the enclosed information will allow your continued and uninterrupted use of these cask models. Should you have any questions regarding this information, please feel free to contact Ms. Susan Kintner at (803) 758-1822.

Very truly yours,

Patrick L. Paquin
General Manager
Engineering and Packaging Licensing

Enclosures: As stated



July 7, 1999

**CHEM-NUCLEAR SYSTEMS INFORMATION NOTICE
POTENTIAL PROBLEMS ASSOCIATED WITH CASK SHIELD INSERTS**

Dear Customer,

For many years, cask shield inserts have been approved for use in certified Low Level Waste Transportation Casks as supplemental shielding or shoring. Several models of Chem-Nuclear Systems (Chem-Nuclear) casks use approved full height shield inserts of varying thicknesses from ½ inch to 2 inches. Cask users have experienced normal fit and function with these inserts, which typically allow for a radial clearance of ½ inch between the insert and the packaging liner. However, specific applications can produce close fitting contents (packaging liners) with minimal dimensional clearances.

Recent experience has shown that, if not properly handled and stored during routine use, cask shield inserts may experience some distortion such as ovalization. This is more pronounced in thinner inserts (i.e. ½ inch thick). This ovalization may however not be readily discernable and may occur by laying the shield insert down on its side without proper reinforcement, resulting in a slight, permanent egg shape.

DESCRIPTION OF POTENTIAL SCENARIO

To characterize the concern, the following scenario is provided which illustrates the potential problem.

A packaging liner (e.g. a 14-170LPRCT liner which consists of a 14-170 HIC inside of a steel shell with an OD of 74 inches) is inserted into a cask which has an out-of-round insert. The typical ½ inch radial clearance would not be achieved. The liner could make contact with the shield insert wall without being noticed and, due to its weight, still slide down sufficiently within the insert and the cask.

During off-load operation, friction or binding between the liner wall and the insert wall may be sufficient to cause the shield insert to be withdrawn as the liner is withdrawn. **THIS CAN POTENTIALLY BE A DANGEROUS SITUATION.** It may not be quickly recognized that the shield insert is being withdrawn with the liner. Under such circumstances, withdrawal may continue until the liner and insert are above the cask lid opening with the potential for the insert to spring loose from the liner and fall free. As a result, severe damage may occur to personnel, the cask or associated equipment from the 2,700 pound insert.

RECOMMENDED ACTIONS FOR USERS

While the example used to demonstrate the concern involves a liner which would be shipped in a 14-195, 14-215 or similar cask, Chem-Nuclear is advising that any shield insert may, if not properly handled, exhibit this potential safety hazard during off-load. Chem-Nuclear recommends that additional care be taken at any time a liner is removed from a cask fitted with a shield insert. Furthermore, Chem-Nuclear recommends that all shield inserts used with the 14-170LPRCT in particular be inspected and gauged for roundness prior to assembly into a cask.

It is our understanding that Customers may be using several older model LPRCT liners (without the smaller OD) with casks fitted with shield inserts provided from sources other than Chem-Nuclear. We recommend that all end users and intermediate handlers incorporate cautionary steps into appropriate procedures for the inspection and gauging of these assemblies before use.

ACTIONS TAKEN BY CHEM-NUCLEAR

Chem-Nuclear has taken the following actions to prevent the described scenario:

- Designed a no-go gauge for shield inserts to be used with the 14-170LPRCT.
- Developed a procedure for use of the no-go gauge, which in addition stipulates pertinent inspection criteria and cautions to be taken during shield insert handling and cask loading and off-loading.
- Revised the 14-170LPRCT shell / baseplate interface design to provide an additional $\frac{1}{4}$ inch of clearance.

Chem-Nuclear is confident that the implementation of these recommendations will help prevent the inadvertent removal of shield inserts when off-loading liners from casks.

For additional information, please contact Patrick Paquin at (803) 758-1824.

8-120A Cask

8-120A Cask

The top loading 8-120A cask is designed to accommodate eight drums or a single steel or polyethylene liner. The cask uses a bolted primary lid. The cask is capable of handling payloads up to 20,000 pounds and is certified to meet the DOT requirements as a 7A, IP-1 and IP-2 package.

Classification: DOT 7A, IP-1 & IP-2
Internal Dimensions: 62.00"D x 75.00" H
Drum Capacity: 8 (55-gal)
PB Shielding Equivalence: 4.50
Approximate Maximum R/Hr based on 10% Cobalt 60: 24 (400-storage only)
Approximate Maximum Empty Weight (lbs): 50,000
Maximum Payload (lbs): 20,000



The following EnergySolutions liners can be used with this cask:

EnergySolutions Liners (PL= polyethylene and L= carbon steel)							
Liners	Height (inches)	Diameter (inches)	Burial Volume (ft³)	Max. Internal Vol (ft³)	Usable Vol (ft³)	Gross Weight (lbs)	Empty Weight (lbs)
L8-120	74.0	61.0	125.2	120.2	112-117	14,500	1,200
L6-80	57.0	58.0	87.2	82.9	62-80	9,900	1,000
PL8-120	73.5	60.0	120.3	107.6	99-101	10,000	600
PL6-80	56.5	57.0	83.4	73.3	62-64	5,000	500

EnergySolutions, LLC
 140 Stoneridge Drive, Suite 500
 Columbia, SC 29210
 Phone: (803) 256-0450

Hittman Transport Services, Inc.
 628 Gallaher Road
 Kingston, TN 37763-4214
 Phone: (865) 376-8106



Website: <http://www.energysolutions.com>



8-120A Cask

8-120A
Concentration vs Isotopic

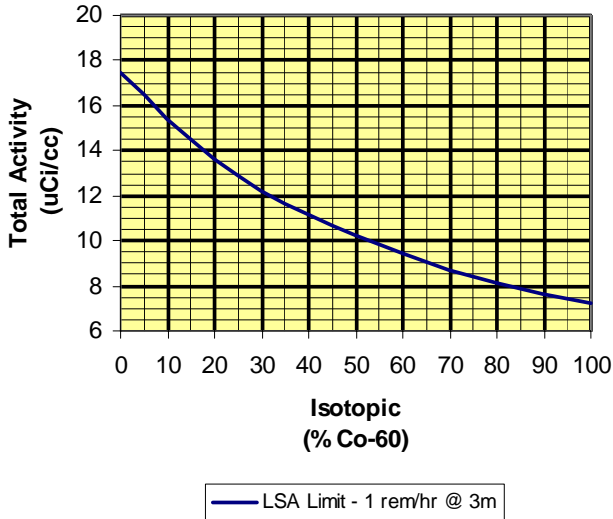

The graphs show the maximum gamma-emitter activity concentration or maximum liner dose rate for dewatered ion-exchange resin that will result in dose rates that are regulatorily acceptable for shipping in this cask. The concentration and dose rate limits are determined by comparison of predicted dose rates to the regulatory limits of 10 mrem/hr at 2 meters from the cask (DOT limit) or 1000 mrem/hr at 3 meters from the unshielded waste (LSA limit), whichever is more restrictive. Waste which exceeds 1000 mrem/hr from the unshielded waste is assumed to also exceed the Type A quantity limit and thus, can not be shipped in a Type A package. For well mixed, uniform concentration waste, shipment of wastes with a gamma activity concentration or liner dose rate below the appropriate curve can be expected to be in compliance with the regulatory limits for dose rates.

8-120A
Liner Dose Rate vs Isotopic

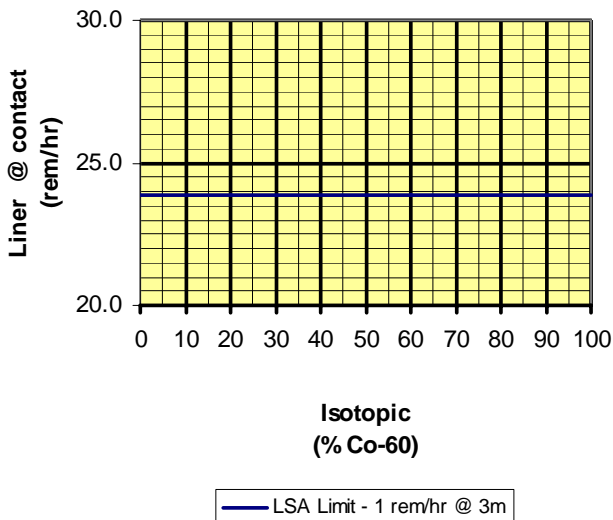

These curves are related to the concentration of ^{60}Co in the waste as compared to the total concentration of gamma emitters. In establishing these curves, the remaining (non- ^{60}Co) gamma isotopes are conservatively assumed to emit one gamma per disintegration with an energy of 1MeV.

Non-gamma emitting isotopes are not included when determining the relative concentration of ^{60}Co . The waste form is assumed to be dewatered ion-exchange resin with a nominal density of 0.6 g/cc. In addition, in modeling the cask to estimate the dose rate outside the cask, the buildup factor was conservatively chosen resulting in a conservative estimate of the dose rate.

The legend of the graph indicates the basis of the curve, i.e., which limit, DOT or LSA, is more restrictive for that case. In some cases, the more restrictive limit varies with the relative isotopic concentration. In this circumstance, the legend indicates both limits.

Energy Solutions, LLC
140 Stoneridge Drive, Suite 500
Columbia, SC 29210
Phone: (803) 256-0450

Hittman Transport Services, Inc.
628 Gallaher Road
Kingston, TN 37763-4214
Phone: (865) 376-8106



Website: <http://www.energysolutions.com>



Section 1

**Conformance with Specifications for
DOT 7A, Type A Packagings**

Approvals Page

**Conformance of CNS 8-120A Cask with Specifications for
DOT 7A, Type A Packagings**

Prepared by:	Signature on File Michael J. Frassica, Project Engineer	4/7/11 Date
Independent Reviewer:	Signature on File Matthew Zwicker, Project Engineer	4/7/11 Date

TABLE OF CONTENTS

1.0 INTRODUCTION.....	3
2.0 DISCUSSION	3
3.0 RESULTS.....	4
4.0 CONCLUSIONS AND RECOMMENDATIONS.....	18
5.0 REFERENCES	18

1.0 Introduction

This report evaluates the CNS 8-120A cask's conformance with 49CFR178.350 "Specification 7A; general packaging, Type A" (Reference 5.1). This report fulfills the requirement of §173.415(a), "Authorized Type A Packages," which specifies that a DOT specification 7A Type A general packaging is an authorized packaging containing quantities not exceeding A₁ or A₂. This section further specifies that:

Each offeror of a Specification 7A package must maintain on file for at least one year after the latest shipment, and shall provide to DOT on request, complete documentation of tests and an engineering evaluation or comparative data showing that the construction methods, packaging design, and materials of construction comply with that specification.

2.0 Discussion

The CNS 8-120A was initially licensed by the US NRC under Certificate of Compliance USA\6601\A. This license expired on April 1, 1999 as a consequence of regulatory changes that result in the NRC no longer licensing Type A packages. The CNS 8-120A was certified as a Type A package by demonstrating compliance with NRC Type A requirements, including 10CFR71.43, "General Standards for All Packages," and 10CFR71.71, "Normal Conditions of Transport." Therefore, the CNS 8-120A should readily meet the requirements for a DOT 7A package. Nevertheless, this report examines each regulatory requirement individually to assess the package's conformance to DOT 7A specifications. However, where appropriate, references are made to the Safety Analysis Report for the CNS 8-120A (Reference 5.2) that was originally prepared to support certification by the NRC.

DOT Specification 7A packages are allowed by §173.431 to exceed A₁ or A₂ quantities in the contents as long as the contents are LSA or SCO and are less than one rem/hr at three meters from the unshielded material. However, the shipper is also responsible for ensuring that the contents do not exceed any of the limits placed on the contents by the analyses in this report.

The applicable requirements for DOT 7A packagings is given in 49CFR178.350, which is as follows:

Each packaging must meet all applicable requirements of subpart B of Part 173 of this subchapter and be designed and constructed so that it meets the requirements of §§173.403, 173.410, 173.412, 173.415 and 173.465 of this subchapter for Type A packaging.

Also, §173.410 requires packages transporting Class 7 (radioactive) materials to meet Subparts A and B of §173. Therefore, in addition to §178.350, the requirements for DOT 7A packagings are given in the following sections of §173:

Subpart A: General

Subpart B: Preparation of Hazardous Materials for Transportation

- 173.403: Definitions
- 173.410: General Design Requirements
- 173.412: Additional Design Requirements for Type A Packages
- 173.415: Authorized Type A Packages
- 173.465: Type A Packaging Tests
- 178.350 Specification 7A; general packaging, Type A

The CNS 8-120A is assessed in Section 3.0 below of this report against each the above requirements. (The requirements of §173.403 are not evaluated, since it contains only definitions rather than specifications.) The methods for demonstrating compliance with the test requirements of §173.465 are given in §173.461. These are; (1) performance of tests, (2) reference to a previous, satisfactory, demonstration of compliance, (3) performance of tests with models, or (4) calculations or reasoned evaluation. The primary method used in this report is method number 4, or reference to the cask SAR which also primarily uses method 4.

3.0 Results

49CFR173, Subpart A: General

Subpart A does not include any prescriptive specifications for the package.

Part 173 Subpart B: Preparation of Hazardous Materials for Transportation

173.21 Forbidden materials and packages.

This section contains specifications that are either not applicable to the 8-120A, or that must be met by the shipper relative to contents of a shipment.

173.22 Shipper's responsibility.

This section contains specifications that must be met by the shipper.

173.22a Use of packagings authorized under exemptions.

This section is not applicable to the CNS 8-120A.

173.23 Previously authorized packaging.

This section is not applicable to the CNS 8-120A.

173.24 General requirements for packagings and packages.

(a) Applicability. Except as otherwise provided in this subchapter, the provisions of this section apply to-

- (1) Bulk and non-bulk packagings;*
- (2) New packagings and packagings which are reused; and*
- (3) Specification and non-specification packagings.*

The CNS 8-120A is classified as a bulk packaging, therefore this section is applicable.

(b) Each package used for the shipment of hazardous materials under this subchapter shall be designed, constructed, maintained, filled, its contents so limited, and closed, so that under conditions normally incident to transportation-

(1) Except as otherwise provided in this subchapter, there will be no identifiable (without the use of instruments) release of hazardous materials to the environment;

(2) The effectiveness of the package will not be substantially reduced; for example, impact resistance, strength, packaging compatibility, etc. must be maintained for the minimum and maximum temperatures, changes in humidity and pressure, and shocks, vibrations, normally encountered during transportation;

(3) There will be no mixture of gases or vapors in the package which could, through any credible spontaneous increase of heat or pressure, significantly reduce the effectiveness of the packaging.

(4) There will be no hazardous residue adhering to the outside of the package during transport.

This specification is demonstrated to be met by the CNS 8-120A SAR as discussed under the requirements of §173.465. In addition, prior to transport, the exterior of the package is checked to assure that all radiation and surface contamination levels are within the limits of applicable regulations.

(c) Authorized packagings. A packaging is authorized for a hazardous material only if-

(1) The packaging is prescribed or permitted for the hazardous material in a packaging section specified for that material in Column 8 of the §172.101 Table and conforms to applicable requirements in the special provisions of Column 7 of the §172.101 Table and, for specification packagings (but not including UN standard packagings manufactured outside the United States), the specification requirements in parts 178 and 179 of this subchapter; or

(2) The packaging is permitted under, and conforms to, provisions contained in §§171.11, 171.12, 171.12a, 173.3, 173.4, 173.5, 173.7, 173.27, or 176.11 of this subchapter.

Table 8 specifies the applicable packaging specifications and exceptions for a hazardous materials being addressed (for example, Radioactive Material, LSA, n.o.s.).

(d) Specification packagings and UN standard packagings manufactured outside the U.S.

(1) Specification packagings. A specification packaging, including a UN standard packaging manufactured in the United States, must conform in all details to the applicable specification or standard in part 178 or part 179 of this subchapter.

(2) UN standard packagings manufactured outside the United States. A UN standard packaging manufactured outside the United States, in accordance with national or international regulations based on the UN Recommendations (see §171.7 of this subchapter) may be imported and used and is considered to be an authorized packaging under the provisions of paragraph (c)(1) of this section, subject to the following conditions and limitations:

(i) The packaging fully conforms to applicable provisions in the UN Recommendations and the requirements of this subpart, including reuse provisions;

(ii) The packaging is capable of passing the prescribed tests in part 178 of this subchapter applicable to that standard; and

(iii) The competent authority of the country of manufacture provides reciprocal treatment for UN standard packagings manufactured in the U.S.

The CNS 8-120A package meets the specification requirements of §178.350 for Specification 7A packages.

(e) Compatibility.

(1) Even though certain packagings are specified in this part, it is, nevertheless, the responsibility of the person offering a hazardous material for transportation to ensure that such packagings are compatible with their lading. This particularly applies to corrosivity, permeability, softening, premature aging and embrittlement.

(2) Packaging materials and contents must be such that there will be no significant chemical or galvanic reaction between the materials and contents of the package.

(3) Plastic packagings and receptacles.

(i) Plastic used in packagings and receptacles must be of a type compatible with the lading and may not be permeable to an extent that a hazardous condition is likely to occur during transportation, handling or refilling.

(ii) Each plastic packaging or receptacle which is used for liquid hazardous materials must be capable of withstanding without failure the procedure specified in appendix B of this part ("Procedure for Testing Chemical Compatibility and Rate of Permeation in Plastic Packagings and Receptacles"). The procedure specified in appendix B of this part must be performed on each plastic packaging or receptacle used for Packing Group I materials. The maximum rate of permeation of hazardous lading through or into the plastic packaging or receptacles may not exceed 0.5 percent for materials meeting the definition of a Division 6.1 material according to §173.132 and 2.0 percent for other hazardous materials, when subjected to a temperature no lower than-

(A) 18 °C (64 °F) for 180 days in accordance with Test Method 1 in appendix B of this part;

(B) 50 °C (122 °F) for 28 days in accordance with Test Method 2 in appendix B of this part;

or

(C) 60 °C (140 °F) for 14 days in accordance with Test Method 3 in appendix B of this part.

(iii) Alternative procedures or rates of permeation are permitted if they yield a level of safety equivalent to or greater than that provided by paragraph (e)(3)(ii) of this section and are specifically approved by the Associate Administrator.

(4) Mixed contents. Hazardous materials may not be packed or mixed together in the same outer packaging with other hazardous or nonhazardous materials if such materials are capable of reacting dangerously with each other and causing-

(i) Combustion or dangerous evolution of heat;

(ii) Evolution of flammable, poisonous, or asphyxiant gases; or

(iii) Formation of unstable or corrosive materials.

(5) Packagings used for solids, which may become liquid at temperatures likely to be encountered during transportation, must be capable of containing the hazardous material in the liquid state.

The above section contains specifications that must be met by the shipper.

173.24(f) Closures.

(1) Closures on packagings shall be so designed and closed that under conditions (including the effects of temperature, pressure and vibration) normally incident to transportation-

(i) Except as provided in paragraph (g) of this section, there is no identifiable release of hazardous materials to the environment from the opening to which the closure is applied; and

(ii) The closure is secure and leakproof and secured against loosening. For air transport, stoppers, corks or other such friction closures must be held in place by positive means.

Compliance to subparagraph (1) is demonstrated by performance of an annual cask inspection, as well as a periodic inspection, for any condition, which would prevent formation of a seal between the sealing surface and the gasket. Furthermore, prior to each shipment, a gasket and seal surface inspection is performed in accordance with the cask's operating procedure.

(2) Except as otherwise provided in this subchapter, a closure (including gaskets or other closure components, if any) used on a specification packaging must conform to all applicable requirements of the specification and must be closed in accordance with information, as applicable, provided by the manufacturer's notification required by §178.2 of this subchapter.

As discussed in the SAR under the requirements of §173.412 and 173.465, the package meets the requirements of this section.

(g) Venting. Venting of packagings, to reduce internal pressure which may develop by the evolution of gas from the contents, is permitted only when-

(1) Transportation by aircraft is not involved;

(2) Except as otherwise provided in this subchapter, the evolved gases are not poisonous, likely to create a flammable mixture with air or be an asphyxiant under normal conditions of transportation;

(3) The packaging is designed so as to preclude an unintentional release of hazardous materials from the receptacle; and

(4) For bulk packagings other than IBCs, venting is authorized for the specific hazardous material by a special provision in the §172.101 Table or by the applicable bulk packaging specification in part 178 of this subchapter.

Not applicable.

(h) Outage and filling limits

(1) General. When filling packagings and receptacles for liquids, sufficient ullage (outage) must be left to ensure that neither leakage nor permanent distortion of the packaging or receptacle will occur as a result of an expansion of the liquid caused by temperatures likely to be encountered during transportation. Requirements for outage and filling limits for non-bulk and bulk packagings are specified in §§173.24a(d) and 173.24b(a), respectively.

(2) Compressed gases and cryogenic liquids. Filling limits for compressed gases and cryogenic liquids are specified in §§173.301 through 173.306 for cylinders and §§173.314 through 173.319 for bulk packagings.

(i) Air transportation. Except as provided in §171.11 of this subchapter, packages offered or intended for transportation by aircraft must conform to the general requirements for transportation by aircraft in §173.27.

Refer to the discussions in §173.24(b).

173.24a Additional general requirements for non-bulk packagings and packages.

Not applicable; the CNS 8-120A is classified as a bulk packaging.

173.24b Additional general requirements for bulk packagings.

This section contains specifications that must be met by the shipper.

173.25 Authorized packages and overpacks.

Not applicable; this section addresses specifications for overpacks and the package is not classified as an overpack.

173.26 Quantity limitations.

When quantity limitations do not appear in the packaging requirements of this subchapter, the permitted gross weight or capacity authorized for a packaging is as shown in the packaging specification or standard in part 178 or 179, as applicable, of this subchapter.

The permitted capacity and gross weight is given in Chapter 2 of the SAR and marked on the package nameplate.

173.27 General requirements for transportation by aircraft.

Not applicable; the CNS 8-120A is not designed to be transported by aircraft.

173.28 Reuse, reconditioning and remanufacture of packagings.

(a) General. Packagings and receptacles used more than once must be in such condition, including closure devices and cushioning materials, that they conform in all respects to the prescribed requirements of this subchapter. Before reuse, each packaging must be inspected and may not be reused unless free from incompatible residue, rupture, or other damage which reduces its structural integrity.

The package is inspected before each reuse.

(b) Reuse of non-bulk packaging. A non-bulk packaging used more than once must conform to the following provisions and limitations:

Not applicable; the package is classified as a bulk package.

173.29 Empty packagings.

This section contains specifications that must be met by the shipper.

173.30 Loading and unloading of transport vehicles.

A person who loads or unloads hazardous materials into or from a transport vehicle or vessel shall comply with the applicable loading and unloading requirements of parts 174, 175, 176, and 177 of this subchapter.

This section contains specifications that must be met by the shipper.

173.31 Use of tank cars.

Not applicable.

173.32 Requirements for the use of portable tanks.

Not applicable.

173.33 Hazardous materials in cargo tank motor vehicles.

Not applicable.

173.34 [Reserved]

Not applicable.

173.35 Hazardous materials in intermediate bulk containers.

Not applicable.

173.40 General packaging requirements for toxic materials packaged in cylinders.

Not applicable.

173.410 General design requirements.

In addition to the requirements of subparts A and B of this part, each package used for the shipment of Class 7 (radioactive) materials must be designed so that-

(a) The package can be easily handled and properly secured in or on a conveyance during transport.

The cask is equipped with lifting attachments for handling. It is tied down to the trailer deck during transport. The tiedown system is evaluated structurally in Section 2.4.4 of the Safety Analysis Report (SAR).

(b) Each lifting attachment that is a structural part of the package must be designed with a minimum safety factor of three against yielding when used to lift the package in the intended manner, and it must be designed so that failure of any lifting attachment under

excessive load would not impair the ability of the package to meet other requirements of this subpart. Any other structural part of the package which could be used to lift the package must be capable of being rendered inoperable for lifting the package during transport or must be designed with strength equivalent to that required for lifting attachments.

Section 2.4.3 of the SAR demonstrates that the structural requirements of the lifting attachments are met. Failure of the lifting attachment will not impair the ability of the package to meet other requirements of this subpart. There are no other structural parts of the package that could be used to lift it.

(c) The external surface, as far as practicable, will be free from protruding features and will be easily decontaminated.

The external surfaces of the package are free of protruding features, except those necessary for the package to perform its function. The external surfaces are hard and smooth and therefore easily decontaminated.

(d) The outer layer of packaging will avoid, as far as practicable, pockets or crevices where water might collect.

There are no pockets or crevices on the outer layer of the packaging where water might collect.

(e) Each feature that is added to the package will not reduce the safety of the package.

Features of the package are evaluated in the SAR, and it was determined that there are none that reduce its safety.

(f) The package will be capable of withstanding the effects of any acceleration, vibration or vibration resonance that may arise under normal conditions of transport without any deterioration in the effectiveness of the closing devices on the various receptacles or in the integrity of the package as a whole and without loosening or unintentionally releasing the nuts, bolts, or other securing devices even after repeated use (see §§173.24, 173.24a, and 173.24b).

The package is similar to many other proven casks with many years of operational use in a transport environment. This experience demonstrates that vibrations normally incident to transport will have no effect upon the package.

(g) The materials of construction of the packaging and any components or structure will be physically and chemically compatible with each other and with the package contents. The behavior of the packaging and the package contents under irradiation will be taken into account.

The package is constructed of structural steel and the exterior is primed and painted. As discussed in 2.4.1 of the SAR, there will be no reactions between the package and contents nor between the package components.

(h) All valves through which the package contents could escape will be protected against unauthorized operation;

There are no valves in the package.

(i) For transport by air-

Not Applicable, 8-120A is not transported by air.

173.412 Additional design requirements for Type A packages.

In addition to meeting the general design requirements prescribed in §173.410, each Type A packaging must be designed so that-

(a) The outside of the packaging incorporates a feature, such as a seal, that is not readily breakable, and that, while intact, is evidence that the package has not been opened. In the case of packages shipped in closed transport vehicles in exclusive use, the cargo compartment, instead of the individual packages, may be sealed.

Tamper-indicating seals are provided for the closures. Installation of these prior to shipment are required by Chapter 7 of the SAR.

(b) The smallest external dimension of the package is not less than 10 centimeters (4 inches).

The smallest external dimension exceeds 4”.

(c) Containment and shielding is maintained during transportation and storage in a temperature range of -40 °C (-40 °F) to 70 °C (158 °F). Special attention shall be given to liquid contents and to the potential degradation of the packaging materials within the temperature range.

This is the same requirement as 10CFR71.43, “General Standards for All Packages,” paragraph (h), and 10CFR71.71, “Normal Conditions of Transport,” paragraph (c)(2). The package has been previously approved by the NRC as meeting the requirements of these paragraphs. As discussed in Sections 2.6.1 and 2.6.2 of the SAR, the components of the package are designed to maintain containment and shielding during transportation and storage in the temperature range specified in this paragraph.

(d) The packaging must include a containment system securely closed by a positive fastening device that cannot be opened unintentionally or by pressure that may arise within the package during normal transport. Special form Class 7 (radioactive) material, as demonstrated in accordance with §173.469, may be considered as a component of the containment system. If the containment system forms a separate unit of the package, it must be securely closed by a positive fastening device that is independent of any other part of the package.

As discussed in Sections 1.2.1 and 2.4.2 of the SAR, the cask is equipped with positive fastening devices. These consist of the thirty-two bolts for the lid.

(e) For each component of the containment system account is taken, where applicable, of radiolytic decomposition of materials and the generation of gas by chemical reaction and radiolysis.

The cask is evaluated in the next paragraph (f) of the SAR for an internal pressure of 11.1 psig.

(f) The containment system will retain its radioactive contents under the reduction of ambient pressure to 25 kPa (3.6 pounds per square inch).

The following evaluation is performed to show that the cask can safely withstand a reduced external pressure of 3.6 psi. An external pressure of 3.6 psi is equivalent to an internal pressure of 11.1 psig. At an internal pressure of 11.1 psig, the load on the lid bolts will be:

$$P = \frac{A p}{N} \quad \text{where} \quad A = \text{area of lid}$$
$$N = \text{number of bolts} = 32$$

The load on the lid bolts will be:

$$P_{PB} = \frac{\pi(62)^2}{4} \frac{(11.1)}{(32)} = 1047 \text{ lbs}$$

The tensile strength of the 1³/₄ - 5, Grade L7 bolts is: (125,000)(1.49) = 186,250 lbs

The margin of safety is:

$$M.S. = \frac{186,250}{1047} - 1 = 177$$

Conservatively assume that the 11.1 psig internal pressure is entirely contained by the 1/2-inch thick inner shell:

$$\text{longitudinal stress} = \frac{P R}{t} = \frac{(11.1) (62/2)}{0.5} = 688 \text{ psi}$$

$$\text{hoop stress} = \frac{P R}{2t} = 344 \text{ psi}$$

Assuming the stresses are additive, the maximum stress in the cask inner wall is 1032 psi. The margin of safety will be:

$$M.S. = \frac{32,000}{1032} - 1 = 30$$

These analyses show the cask can safely withstand a reduced external pressure of 3.6 psi.

(g) Each valve, other than a pressure relief device, is provided with an enclosure to retain any leakage.

Not applicable. There are no valves on the package.

(h) Any radiation shield that encloses a component of the packaging specified as part of the containment system will prevent the unintentional escape of that component from the shield.

The outer shell and lead act as shielding and contain the inner shell, which forms part of the containment.

(i) Failure of any tie-down attachment that is a structural part of the packaging, under both normal and accident conditions, must not impair the ability of the package to meet other requirements of this subpart.

Failure of the tie-down lugs will be by localized tearing and will not impair the ability of the package to meet other requirements of this subpart.

(j) When evaluated against the performance requirements of this section and the tests specified in §173.465 or using any of the methods authorized by §173.461(a), the packaging will prevent-

(1) Loss or dispersal of the radioactive contents; and

(2) A significant increase in the radiation levels recorded or calculated at the external surfaces for the condition before the test.

The tests specified in §173.465 are evaluated in Chapters 2, 3, 4, and 5 of the SAR, where it is shown that the cask can successfully pass these tests without loss or dispersal of the radioactive contents and without a significant increase in the radiation levels recorded or calculated at the external surfaces for the condition before the test. This is demonstrated by analysis for the conditions specified as allowed by §173.461(a).

(k) Each packaging designed for liquids will-

(1) Be designed to provide for ullage to accommodate variations in temperature of the contents, dynamic effects and filling dynamics;

(2) Meet the conditions prescribed in paragraph (j) of this section when subjected to the tests specified in §173.466 or evaluated against these tests by any of the methods authorized by §173.461(a); and

(3) Either-

(i) Have sufficient suitable absorbent material to absorb twice the volume of the liquid contents. The absorbent material must be compatible with the package contents and suitably positioned to contact the liquid in the event of leakage; or

(ii) Have a containment system composed of primary inner and secondary outer containment components designed to assure retention of the liquid contents within the secondary outer component in the event that the primary inner component leaks.

Not applicable.

(l) Each package designed for gases, other than tritium not exceeding 40 TBq (1080Ci) or noble gases not exceeding the A_2 value appropriate for the noble gas, will be able to

prevent loss or dispersal of contents when the package is subjected to the tests prescribed in §173.466 or evaluated against these tests by any of the methods authorized by §173.461(a).

Not applicable.

173.415 Authorized Type A packages.

The following packages are authorized for shipment if they do not contain quantities exceeding A₁ or A₂ as appropriate:

(a) DOT Specification 7A (§178.350 of this subchapter) Type A general packaging. Each offeror of a Specification 7A package must maintain on file for at least one year after the latest shipment, and shall provide to DOT on request, complete documentation of tests and an engineering evaluation or comparative data showing that the construction methods, packaging design, and materials of construction comply with that specification. Use of Specification 7A packagings designed in accordance with the requirements of §178.350 of this subchapter in effect on June 30, 1983 (see 49 CFR Part 178 revised as of October 1, 1982), is not authorized after April 1, 1997.

This report and the cask's SAR should be retained by the shipper to meet the requirements of this paragraph. Note also the exception allowed by §173.431 is that a DOT 7A package can exceed A₁ or A₂ quantities in the contents if the contents are LSA or SCO materials.

(b) Any other Type A packaging that also meets the applicable standards for fissile materials in 10 CFR Part 71 and is used in accordance with §173.471.

Not applicable to the CNS 8-120A package.

(c) Any Type B, B(U) or B(M) packaging authorized pursuant to §173.416.

Not applicable to the CNS 8-120A package.

(d) Any foreign-made packaging that meets the standards in "IAEA Regulations for the Safe Transport of Radioactive Material No. TS-R-1" (IBR, see § 171.7 of this subchapter) and bears the marking "Type A". Such packagings may be used for domestic and export shipments of Class 7 (radioactive) materials provided the offeror obtains the applicable documentation of tests and engineering evaluations and maintains the documentation on file in accordance with paragraph (a) of this section. These packagings must conform with requirements of the country of origin (as indicated by the packaging marking) and the IAEA regulations applicable to Type A packagings.

Not applicable to the CNS 8-120A package.

173.465 Type A packaging tests.

(a) *The packaging, with contents, must be capable of withstanding the water spray, free drop, stacking and penetration tests prescribed in this section. One prototype may be used for all tests if the requirements of paragraph (b) of this section are met.*

(b) *Water spray test. The water spray test must precede each test or test sequence prescribed in this section. The water spray test must simulate exposure to rainfall of approximately 5 centimeters (2 inches) per hour for at least one hour. The time interval between the end of the water spray test and the beginning of the next test must be such that the water has soaked in to the maximum extent without appreciable drying of the exterior of the specimen. In the absence of evidence to the contrary, this interval may be assumed to be two hours if the water spray is applied from four different directions simultaneously. However, no time interval may elapse if the water spray is applied from each of the four directions consecutively.*

As discussed in 2.6.5 of the SAR, the exterior of the package is fabricated from steel and painted. The closure lids are bolted closed and sealed with gaskets. Hence, a water spray will have negligible effects on the package.

(c) *Free drop test. The specimen must drop onto the target so as to suffer maximum damage to the safety features being tested, and:*

(1) *The height of the drop measured from the lowest point of the specimen to the upper surface of the target may not be less than the distance specified in Table 10, for the applicable package mass. The target must be as specified in §173.465(c)(5). Table 10 is as follows:*

<i>Packaging mass Kilograms (pounds)</i>	<i>Free drop distance</i>	
	<i>Meters</i>	<i>Feet</i>
<i><Mass 5000 (11,000)</i>	<i>1.2</i>	<i>4</i>
<i>5,000 (11,000) Mass to 10,000(22,000)</i>	<i>0.9</i>	<i>3</i>
<i>10,000 (22,000) Mass to 15,000(33,000)</i>	<i>0.6</i>	<i>2</i>
<i>>15,000 (33,000) Mass</i>	<i>0.3</i>	<i>1</i>

Sections 2.6.6 and 2.6.7 of the SAR examines the package for the one foot free drop and corner drop. The analyses for show that the package can successfully withstand and maintain package integrity for the specified one foot drop.

(2) *For packages containing fissile material, the free drop test specified in paragraph (c)(1) of this section must be preceded by a free drop from a height of 0.3 meter (1 foot) on each corner, or in the case of cylindrical packages, onto each of the quarters of each rim.*

Not applicable for the CNS 8-120A package.

(3) For fiberboard or wood rectangular packages with a mass of 50 kilograms (110 pounds) or less, a separate specimen must be subjected to a free drop onto each corner from a height of 0.3 meter (1 foot).

Not applicable for the CNS 8-120A package.

(4) For cylindrical fiberboard packages with a mass of 100 kilograms (220 pounds) or less, a separate specimen must be subjected to a free drop onto each of the quarters of each rim from a height of 0.3 meter (1 foot).

Not applicable for the CNS 8-120A package.

(5) The target for the free drop test must be a flat, horizontal surface of such mass and rigidity that any increase in its resistance to displacement or deformation upon impact by the specimen would not significantly increase the damage to the specimen.

The analyses performed was for a drop onto an essentially unyielding surface.

(d) Stacking test.

(1) The specimen must be subjected for a period of at least 24 hours to a compressive load equivalent to the greater of the following:

(i) Five times the mass of the actual package; or

(ii) The equivalent of 13 kilopascals (1.9 pounds per square inch) multiplied by the vertically projected area of the package.

(2) The compressive load must be applied uniformly to two opposite sides of the specimen, one of which must be the base on which the package would normally rest.

Max Package Mass - 74,000 lbs, Diameter of cask - 74.5 inches

Inner shell of cask 1/2 inch thick, 62.5 inches nominal diameter (31.25" radius), Mat'l - ASTM A516-Gr. 60 (yield = 32,000 psi)

§ 173.465 (d)(i) 74,000 lb X 5 = 370,000 lbs

§ 173.465 (d)(ii) $1.9_{\text{psi}} \times \left(\frac{\pi \times 74.5^2}{4} \right) = 8,283 \text{ lbs}$

Evaluate package using most severe loading condition, (i).

To evaluate cask for buckling under 5X package load, the cask is modeled as thin-walled circular tube under uniform longitudinal compression, *Roaks's Formulas for Stress and Strain*, Young W., Budynas R. 7th Ed. (Table 15.2, case 15)

Inner shell of cask 1/2 inch thick, 62.5 inches nominal diameter (31.25" radius), Mat'l - ASTM A516-Gr. 60 (yield = 32,000 psi)

Conservatively only evaluate 1/2 inch thick inside shell of cask.

For validity of formula, $\frac{r}{t} > 10$, $\frac{31.25}{0.5} \gg 10$

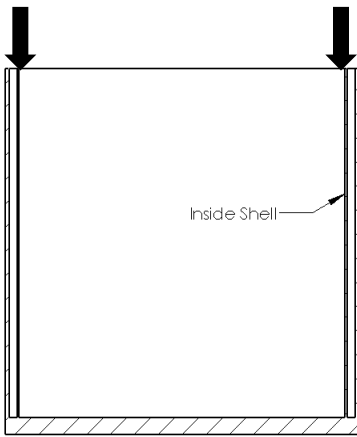

where 'r' is radius and 't' is thickness of shell, reference formula valid.

Determining critical buckling stress (σ_{cr}) using case 15.

$$\sigma_{cr} = 0.3 \times \frac{E \times t}{r}$$

where 'E' is modulus of elasticity in pounds per square inch (psi).

$$\sigma_{cr} = 0.3 \times \frac{(30 \times 10^6) \times 0.5}{31.25} = 144,000 \text{ psi}$$

$\sigma_{cr} \gg \sigma_{yield}$ therefore evaluate using yield strength of material.

Calculate stress induced by 5X loading (σ_{5X})

$$\sigma_{5X} = \frac{370,000 \text{ lbs}}{\left(\frac{\pi \times 63.5^2}{4} - \frac{\pi \times 62.5^2}{4} \right)} = 3,739 \text{ psi}$$

$\sigma_{yield} \gg \sigma_{5X}$ 8-120A cask body will not buckle under 5X loading, meets §173.465 (d)

The 8-120A cask package is supplied and shipped with a dedicated conveyance trailer. As such, the package and trailer are integrated during operations as guided by cask handling procedure. The package is not intended to be stacked one on top of the other, however the package is capable of using an interface which allows for stacking and load distributing to comply to §173.465 (d) as demonstrated above.

$\sigma_{yield} \gg \sigma_{5X}$ 8-120A cask body will not buckle under 5X loading, meets §173.465 (d)

The 8-120A cask package is supplied and shipped with a dedicated conveyance trailer. As such, the package and trailer are integrated during operations as guided by cask handling procedure. The package is not intended to be stacked one on top of the other, however the package is capable of using an interface which allows for stacking and load distributing to comply to §173.465 (d) as demonstrated above.

(e) Penetration test. For the penetration test, the specimen must be placed on a rigid, flat, horizontal surface that will not move significantly while the test is being performed.

(1) A bar of 3.2 centimeters (1.25 inches) in diameter with a hemispherical end and a mass of 6 kilograms (13.2 pounds) must be dropped and directed to fall with its longitudinal axis vertical, onto the center of the weakest part of the specimen, so that, if it penetrates far enough, it will hit the containment system. The bar may not be significantly deformed by the test; and

(2) The height of the drop of the bar measured from its lower end to the intended point of impact on the upper surface of the specimen must be 1 meter (3.3 feet) or greater.

As discussed in Section 2.6.8 of the package SAR examines the impact of a 13 lb steel bar (1.25 in diameter) dropped from a height of 3.3 ft onto the package side exterior wall will have minimal effect on the cask. Thus, the integrity of the package will not be affected by this test.

4.0 Conclusions and Recommendations

The requirements of §178.350(b) are that:

Each Specification 7A packaging must be marked on the outside "USA DOT 7A Type A" and "Radioactive Material."

The conclusion of this report is that the CNS 8-120A meets the specification requirements for a DOT 7A package and can be marked as required by §178.350(b).

5.0 References

- 5.1 Code of Federal Regulations, Title 49, Parts 100 through 185, October 1, 2010. |
- 5.2 Safety Analysis Report for Chem-Nuclear Systems Model No. CNS 8-120A , Rev. 6, April 2011. |

Section 2

Handling Procedure

Cask Handling Procedure for US DOT Specification 7A, Type A Transportation Cask

Revision 8

Authored By: Signature on File 12/10/10
Michael J. Frassica, Project Engineer Date

Reviewed By: Signature on File 12/10/10
Phillip H. Thomas, Project Engineer Date

Approved By Signature on File 12/10/10
Patrick L. Paquin, GM Engineering & Licensing Date

- New
 Title Change
 Revision
 Rewrite
 Cancellation

Effective
Date 1/14/11

Table of Contents

Section	Page
1. PURPOSE.....	3
2. REFERENCES	3
3. GENERAL.....	4
3.1 Precautions.....	4
3.2 Prerequisites.....	4
3.3 Equipment.....	5
3.4 Personnel.....	5
3.5 Records	7
3.6 Definitions.....	7
4. PROCEDURE.....	8
4.1 Empty Cask Receipt Preliminaries	8
4.2 Empty Cask Receipt Inspection	8
4.3 Radiation Survey.....	8
4.4 Inspect Tie-Downs.....	9
4.5 Inspect Cask.....	9
4.6 Preparing Cask for Payload	11
4.7 Loading the Cask	11
4.8 Loading Drums on Pallets in the Cask.....	13
4.9 Loading Drums on Pallets Outside the Cask	14
4.10 Preparing the Cask and Vehicle for Shipment.....	23
4.11 Loaded Cask Receipt Inspection and Payload Unloading	24
4.12 Gasket Maintenance and Replacement Procedure.....	26
5. ATTACHMENTS.....	26
5.1 Suggested Pre-Release Checklist.....	27
5.2 Impact Limiter Handling.....	28
5.3 Cask Specific Weight and Torquing Information.....	30

1. PURPOSE

1.1 The purpose of this procedure is to provide cask handling operational instructions for loading/unloading the following US Department of Transportation (DOT) Specification 7A, Type A radioactive material transportation casks (DOT-7A, Type A shipping casks):

6-80-2 Series	14-170 Series
8-120A	14-190 Series
10-142A Series	14-210 Series
14D-2.0	14-215
14-195	21-300

1.2 This procedure covers specific steps for:

1.2.1 Empty cask receipt preliminaries (Section 4.1)

1.2.2 Empty cask receipt inspection (Section 4.2)

1.2.3 Preparing the cask for payload (Section 4.6)

1.2.4 Loading the cask (Section 4.7)

1.2.5 Preparing the cask and vehicle for shipment (Section 4.10)

1.2.6 Loaded cask receipt inspection and payload unloading (Section 4.11)

1.2.7 Gasket repair and replacement (Section 4.12)

1.2.8 Gasket sealing surface repair (Section 4.13)

1.3 This procedure may be used in its entirety as is or incorporated into the user's procedures.

2. REFERENCES

2.1 Code of Federal Regulations, Title 49

2.2 Engineering Report Type A evaluation for each cask listed in 1.1

2.3 Technical 3001, Inspection, Maintenance, Repair and Storage for US DOT Specification 7A, Type A Transportation Casks

2.4 ES-TN-PR-001, Training Program

- 2.5 ES-PU-PR-004, Procurement Procedure
- 2.6 CS-QA-WI-005, Measuring and Test Equipment Calibration at the Columbia Maintenance Facility
- 2.7 CMF-RS-PR-6003, CMF Quality Assurance Records
- 2.8 ES-AD-PR-013, Control of Nonconforming Items
- 2.9 TR-MN-005, Gasket/Seal/O-Ring Replacement/Repair Procedure for EnergySolutions Cask Fleet

3. GENERAL

3.1 Precautions

- 3.1.1 Observe all applicable safety precautions including proper lift, rigging, and handling in accordance with site operating procedures.
- 3.1.2 Technicians shall use proper radiological procedures and abide by Radiation Work Permits, if required, to minimize radiation exposure and the spread of contamination.
- 3.1.3 Technicians shall follow all safety rules in the course of their duties and use proper personnel protective equipment as required by Health and Safety requirements, or equivalent, for the task being performed.

3.2 Prerequisites

- 3.2.1 Prior to inspection, ensure that a radiological survey of the equipment has been performed. Use proper personnel protective equipment and ALARA practices as required by Health and Safety requirements for the task being performed.
- 3.2.2 Prior to the implementation of lifting/handling tasks, ensure that all equipment is properly rated for the loads to be handled.
- 3.2.3 Prior to implementing lifting/handling tasks, an inspection of all rigging and components shall be conducted to ensure the components are in good working order and free from defects and damage. Damaged or defective components must be replaced prior to use.
- 3.2.4 Ensure the crane being used is rated for the intended load.

3.3 Equipment

- 3.3.1 Calibrated torque wrench, calibrated for the lowest and highest value required by this procedure.
- 3.3.2 All Measuring and Test Equipment (M&TE) utilized shall be in accordance with Reference 2.6 or applicable site calibrated equipment requirements.
- 3.3.3 Components and/or services necessary for equipment repair and maintenance shall be procured in accordance with Reference 2.5.

3.4 Personnel

- 3.4.1 *EnergySolutions* General Manager, Engineering & Licensing (GM) is responsible for interface with *EnergySolutions* customers regarding equipment conditions, operations, and utilization, for implementation of this procedure, and for ensuring that personnel performing activities associated with the inspection and maintenance of equipment (radwaste shipping casks and transport trailers) have been qualified in accordance with Reference 2.4.
- 3.4.2 *EnergySolutions* Transportation Coordinator is responsible for ensuring that only equipment (Type A shipping casks and transport trailers) which have been properly inspected, maintained, and repaired will be used, or scheduled for use, for the transportation of radioactive materials.

The Transportation Coordinator shall ensure that no Type A shipping cask shall be dispatched with less than thirty (30) days from the date of departure remaining on the Annual inspection without approval from the Facility Manager.

- 3.4.3 *EnergySolutions* Facility Manager is responsible for ensuring that only qualified personnel perform activities associated with the implementation of this procedure.

The Facility Manager is also responsible for tracking the status of Annual (12 month) inspections for Type A using the Type A cask matrix and for ensuring that unacceptable conditions identified during routine inspection are documented in accordance with Reference 2.8.

The Facility Manager shall ensure that no Type A shipping cask shall be dispatched from the CMF with less than thirty (30) days from the date of departure remaining on the Annual inspection.

- 3.4.4 EnergySolutions Cask Maintenance Technician(s) is responsible for performing activities associated with the inspection/handling and routine maintenance of DOT-7A, Type A shipping casks and transport trailers in accordance with the requirements of this procedure and for providing the results to the EnergySolutions Facility Manager. They are also responsible for notifying the EnergySolutions Transportation Coordinator and the transport company of any required maintenance on transport trailers found unacceptable during the course of implementing inspections in accordance with this procedure, for notifying the EnergySolutions Facility Manager, EnergySolutions Engineering & Licensing to provide direction when conditions require input in accordance with this procedure, for notifying EnergySolutions QA personnel when conditions warrant QA involvement in accordance with this procedure, and for the maintenance of records in accordance with this procedure. If a nonconforming condition is identified during the inspection (i.e., an inspection element is determined to be unsatisfactory), it shall be documented per the requirements of Reference 2.8 and the Nonconforming Report number shall be referenced on the inspection report. Replacement of other items (e.g., o-rings, gaskets, ratchet binders, etc.) found to be unsatisfactory during the release inspection may be completed without issuance of a Nonconforming Report, provided that:
- The items are replaced with similar items that satisfy all current design requirements;
 - The replacement is noted in the remarks section of the inspection report, along with a description of the unsatisfactory condition.
- 3.4.5 EnergySolutions Engineering & Licensing Department is responsible for providing direction, instructions, and recommendations for handling and repair of equipment that have non-conformances in accordance with this procedure and for interface with regulatory agencies on matters concerning the DOT-7A, Type A shipping casks.
- 3.4.6 Shipper is responsible for completing all paperwork required for the shipment of radioactive materials utilizing DOT-7A, Type A shipping casks and associated transport trailers, for adhering to all DOT requirements regarding the conveyance of radioactive materials utilizing DOT-7A, Type A shipping casks and associated transport trailers, and for notifying all pertinent parties of unacceptable conditions discovered as a result of implementing a pre-delivery inspection in a timely manner and implementing instructions as provided by EnergySolutions.

- 3.4.7 Radiation Protection Personnel are responsible for providing incoming and outgoing release radiological surveys of DOT-7A, Type A shipping casks, associated transport trailers, and other associated equipment, and for providing guidance, direction, and instruction with regard to radiation protection for individuals implementing tasks in accordance with this procedure.
- 3.4.8 User of a DOT-7A, Type A Shipping cask is responsible for ensuring the following:
 - 3.4.8.1 A copy of Reference 2.2 is maintained on file for a minimum of one (1) year after the latest shipment with this cask. This documentation shall be provided to DOT upon request.
 - 3.4.8.2 The cask has been inspected under a Quality Assurance Program (QAP) to verify its compliance with the requirements of References 2.1, 2.2, and 2.3.
 - 3.4.8.3 All documentation required for the shipment is properly completed.
 - 3.4.8.4 The cask is loaded in accordance with this procedure.
 - 3.4.8.5 The shipment meets all the Department of Transportation, Burial Site Disposal Criteria, Burial Site License requirements, and/or any other applicable facility radioactive material license and acceptance requirements.
 - 3.4.8.6 EnergySolutions CMF Facility Manager is notified immediately if there is a problem meeting any of the requirements of this procedure.

3.5 **Records**

All documentation on the cask handling, component replacement, and repair are quality records and shall be maintained in accordance with Reference 2.7.

3.6 **Definitions**

Security Seal(s): Tamper evident device that verifies a cask boundary has been preserved by the recipient matching seal identification number to the originators documentation.

4. PROCEDURE

4.1 Empty Cask Receipt Preliminaries

When ordering the cask, ensure the following:

- 4.1.1 Radioactive material to be shipped in the cask is a Type A quantity [49 CFR 173.403] of radioactive material, Low Specific Activity material or Surface Contaminated Objects with an external dose rate not exceeding 1 rem/hr at three (3) meters from the unshielded material [49 CFR 173.403, 173.427] or a Type A quantity [49 CFR 173.431(a)] of solid Normal or Special Form [49 CFR 173.403] radioactive material. The material may contain fissile material provided it satisfies one of the 49 CFR 173.453 Fissile Exemption conditions.
- 4.1.2 Appropriate Site Licenses and current copies of 10 CFR and 49 CFR are in your possession.
- 4.1.3 Radioactive material is packaged or will be packaged in an acceptable manner in accordance with the Department of Transportation (49 CFR), the applicable burial site requirements (Burial Site Disposal Criteria and/or Licenses), or WAC of consignor.
- 4.1.4 The Cask information is obtained from the *EnergySolutions* Web site.

4.2 Empty Cask Receipt Inspection

Upon receipt, verify:

- 4.2.1 Exterior nameplates, stencils, placards and other required identification is in place and legible.
- 4.2.2 All required documentation is completed and retained/displayed as specified by the regulatory authority and the user.

4.3 Radiation Survey

Survey the empty cask and the vehicle to determine the maximum removable and fixed contamination levels.

- 4.3.1 External loose contamination levels should be within DOT limits.
- 4.3.2 If removable radioactive contamination exceeds DOT limits on the external surfaces of the packages, immediately notify the final delivering

carrier and, as required, the appropriate US DOT office and EnergySolutions Facility Manager.

4.4 Inspect Tie-Downs

- 4.4.1 Inspect tie-down lugs and shackles on casks and trailer for cracks and wear which would affect their strength.
- 4.4.2 Inspect tie-down cables to ensure that they are not loose or damaged (crimped, frayed, etc.).
- 4.4.3 Inspect tie-down ratchets/turnbuckles to ensure that they are in proper working condition.
- 4.4.4 Cotter pins, lock wire, or other appropriate retaining devices installed on all bolts, studs, pins, etc. are not damaged or missing.

Note: Contact EnergySolutions Facility Manager if any defects (noted above) are found in cask tie-down systems for a determination of defect impact on tie-down performance.

4.5 Inspect Cask

- 4.5.1 If cask is equipped with a rain cover, remove it.
- 4.5.2 Inspect ratchet binders that hold the primary cask lid to the body of cask to ensure that they are in proper working condition.
- 4.5.3 Inspect exterior of cask, including any drain or vent port plugs, for defects that might affect the cask integrity or shielding.

Note: Vent and/or drain plug if present does not need to be removed. Visual inspection is adequate.

- 4.5.4 Inspect the primary cask lid hold-down mechanism (i.e. ratchet binders or nuts) to ensure that they are all present and not damaged (i.e. severely corroded, cracked, or deformed).
- 4.5.5 Inspect threadless bolts and lock pins for cracks and wear which would affect their strength.
- 4.5.6 Ensure that cask lid (primary and secondary) lifting lug covers are installed and secured. For the 10-142A Series cask, the impact limiter acts as the cover.

- 4.5.7 Remove the primary cask lid in accordance with Step 4.7.1.
- 4.5.8 Inspect primary cask lid gasket for damage, including cuts, gouges or loss of resiliency that would affect proper sealing. Also inspect the gasket sealing surface for loose, chipped, or scratched painted surfaces, which would affect proper sealing.
- Note: Refer to Step 4.12 if gasket maintenance or replacement is required.**
- 4.5.9 Inspect interior of cask for standing water and foreign material and remove if present.
- Note: Water and foreign material must be removed prior to cask loading.**
- 4.5.10 Inspect interior of cask for obstructions to loading and remove if present.
- 4.5.11 Ensure through inspection that interior of cask is free of defects that might affect the cask integrity or shielding.
- 4.5.12 Inspect the secondary cask lid hold-down nuts and flat washers (if present) to ensure that they are all present and not damaged (i.e. severely corroded, cracked, or deformed).
- 4.5.13 If the secondary cask lid is to be removed or the *EnergySolutions* security seal has been broken, verify that the secondary cask lid gasket has no damage which would affect proper sealing as follows:
- Note: If secondary lid is not removed, do not break security seal to check torque. All other bolts shall be checked**
- 4.5.13.1 Remove the secondary cask lid from the primary cask lid in accordance with Steps 4.9.8.8 through 4.9.8.10.
- 4.5.13.2 Inspect the secondary cask lid hold-down studs for damage, including deformed, scored, or stripped threads, or severe corrosion.
- 4.5.13.3 Inspect the secondary cask lid gasket for damage, including cuts, nicks, chips, indentations, or loss of resiliency, which would affect proper sealing. Also inspect the gasket sealing surface for loose, chipped, or scratched painted surfaces which would affect proper sealing.
- Note: Refer to Step 4.12 if gasket maintenance or replacement is required.**

4.6 Preparing Cask for Payload

If it is necessary to remove the cask from its trailer, proceed as follows:

Note: Contact EnergySolutions Engineering & Licensing before cask is removed from trailer.

- 4.6.1 Loosen tie-down ratchets/turnbuckles as necessary to remove pins from shackles at cask end of tie-down system.
- 4.6.2 Remove pins from shackles.
- 4.6.3 Using the cask lifting lugs and suitable rigging, lift cask off trailer and place cask in proper position for loading.

Note: Empty Cask Weight (with lids installed) is given in Attachment 5.3.

Note: Prior to use of rigging, verify its suitability for the load being lifted and that it has an up-to-date inspection certification for use record. Contact EnergySolutions Facility Manager if guidance is needed.

Note: Do not use the primary cask lid or secondary cask lid lifting lugs to lift cask. The one exception is the 10-142A cask, which is lifted utilizing the three (3) primary lid lifting lugs.

4.7 Loading the Cask

4.7.1 Remove the primary cask lid as follows:

4.7.1.1 If cask is equipped with a rain cover, remove the rain cover from the cask. For casks equipped with impact limiters, perform the steps in Attachment 5.2. Perform Step 4.7.1.1.1 if the primary cask lid hold-down mechanisms use bolts/nuts or Steps 4.7.1.1.2 through 4.7.1.1.6 if the primary cask lid hold-down mechanisms are ratchet binders.

4.7.1.1.1 Loosen and remove hold-down bolts/nuts which secure the primary cask lid. Proceed to Step 4.7.1.2.

4.7.1.1.2 Release each ratchet binder handle from its storage position.

- 4.7.1.1.3 Engage the flip block to the sprocket wheel in the direction necessary to loosen the ratchet binder.

Caution: Ratchet binder handle rotation can become tight when loosening or tightening a ratchet binder. Therefore, visual inspection is necessary to ensure that the ends of the ratchet binder are moving apart when the handle is rotated to loosen the primary lid

- 4.7.1.1.4 Loosen the ratchet binder by pulling the handle in the appropriate direction.

- 4.7.1.1.5 Remove the retaining/lock pin from the threadless bolt (see Figure 4.1).

Figure 4.1

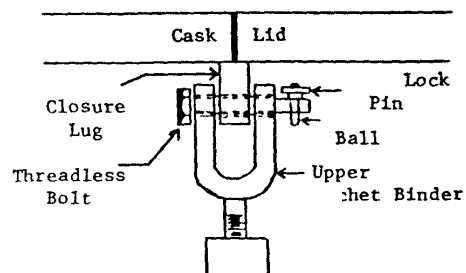

- 4.7.1.1.6 Remove the threadless bolt by pulling the bolt through the holes in the upper ratchet binder connector and lid closure lug (see Figure 4.1).

- 4.7.1.2 Remove the three (3) cask lid lifting lug covers.

- 4.7.1.3 Using the three (3) primary cask lid lifting lugs, suitable rigging, and exercising caution in the handling of the cask lid due to possible contamination of the underside of the lid, remove the primary cask lid.

Note: Primary Cask Lid Weight (with secondary cask lid installed) is given in Attachment 5.3.

Note: Prior to use of rigging, verify its suitability for the load being lifted and that it has an up-to-date inspection/certification for use record. Contact EnergySolutions Facility Manager if guidance is needed.

Note: Care shall be exercised to prevent physical damage to the lid (e.g. bracings / blockings / cushioning).

4.7.1.4 Ensure inspections specified in Steps 4.5.8 to 4.5.11 have been performed.

4.7.2 Cask loading can be accomplished by one of the following methods:

4.7.2.1 If loading drums, install secondary cask lid (if removed) onto primary cask lid in accordance with Steps 4.9.8.13 through 4.9.8.18 and proceed to Step 4.8 or 4.9.

4.7.2.2 If loading waste into container inside the cask, proceed to Step 4.9.8 (omitting Steps 4.9.8.8 through 4.9.8.10 if secondary lid was removed).

4.7.2.3 If loading a preprocessed container, install secondary cask lid (if removed) onto primary cask lid in accordance with Steps 4.9.8.13 through 4.9.8.17 and proceed to Step 4.9.9.

4.8 Loading Drums on Pallets in the Cask

Note: This section addresses the loading of drums into the cask using pallets. Drums may be loaded within the cask without using pallets provided the following are performed: drum slings are positioned to avoid damage; drum slings are easily accessible for drum offload; and drum configuration is as shown in Figure 4.2 or otherwise appropriately shored for transport.

Note: Review Attachment 5.1 or similar site document and shipping papers to ensure that required inspections are performed during the cask loading process and that the information required on the shipping papers is determined.

Note: The total weight of all items placed inside the cask must not exceed the payload limit given in Attachment 5.3.

4.8.1 Inspect pallet slings for damage or wear. Using the slings and exercising caution in the handling of the pallet due to possible contamination, remove the top pallet from the cask.

Note: Do not use suspect slings. Contact EnergySolutions Facility Manager if guidance is needed on a suspect sling condition.

- 4.8.2 Exercising caution to avoid placing drums on the pallet lift slings, load drums on the pallet in the cask (see Figure 4.2 for typical drum placement on a seven (7) drum pallet).

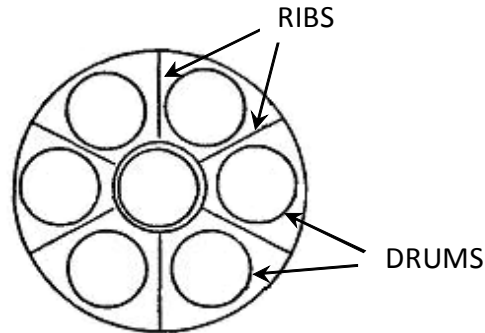

Figure 4.2: Top view of drum configuration on ribbed pallet within cask

Note: Ribless pallets should be loaded with the same drum pattern.

Note: For maximum shielding, load higher dose rate drums in the center position and the positions toward the front and rear of the trailer.

- 4.8.3 Place the top pallet into the cask. Make sure all pallet slings are positioned to avoid damage.
- 4.8.4 Exercising caution to avoid placing drums on the pallet lift slings, load drums on the pallet in the cask (see Figure 4.2).
- 4.8.5 Install the primary cask lid in accordance with Steps 4.9.8.2 through 4.9.8.5.

Note: Cask must be properly sealed prior to shipment.

- 4.8.6 Proceed to Step 4.10.

4.9 Loading Drums on Pallets Outside the Cask

Note: This section addresses the loading of drums into the cask using pallets. Drums may be loaded within the cask without using pallets provided the following are performed: drum slings are positioned to avoid damage; drum slings are easily accessible for drum offload; and drum configuration is as shown in Figure 4.2 or otherwise appropriately shored for transport.

Note: Review Attachment 5.1 or similar site document and the shipping papers to ensure that required inspections are performed during

the cask loading process and that information required on the shipping papers is determined.

Note: The total weight of all items placed inside the cask must not exceed the payload limit given in Attachment 5.3.

4.9.1 Inspect pallet slings for damage or wear. Using slings and exercising caution in the handling of the pallet due to possible contamination, remove both the pallets from the cask.

Note: Do not use suspect slings. Contact EnergySolutions Facility Manager if guidance is needed on a suspect sling condition.

Note: Prior to use of rigging, verify its suitability for the load being lifted and that it has an up-to-date inspection/certification for use record. Contact the regional EnergySolutions Facility Manager if guidance is needed.

4.9.2 Load drums onto each pallet (see Figure 4.2).

4.9.3 Lift one of the loaded pallets and place it inside the cask. For maximum shielding, ensure proper orientation of pallet (see Notes of Figure 4.2). Make sure all pallet slings are positioned to avoid damage.

4.9.4 Lift the other loaded pallet and place it inside the cask on the top of the first pallet. For maximum shielding, ensure proper orientation of pallet (see Notes of Figure 4.2). Make sure all pallet slings are positioned to avoid damage.

4.9.5 Ensure easy access to the pallet lifting slings for removal of pallet.

4.9.6 Install the primary cask lid in accordance with Steps 4.9.8.2 through 4.9.8.5.

Note: Cask must be properly sealed prior to shipment. Additional security seals added by entities other than EnergySolutions Engineering & Licensing shall not alter cask (e.g. drilling new holes in brackets or ratchet binder handles).

4.9.7 Proceed to Step 4.10.

4.9.8 Loading a container to be processed in the cask

Note: Review Attachment 5.1 or similar site document and shipping papers to ensure that required inspections are

performed during the cask loading process and that the information required on the shipping papers is determined.

Note: The total weight of all items placed inside the cask must not exceed the payload limit given in Attachment 5.3.

4.9.8.1 Inspect container slings for damage or wear. Using the slings, place the container in the cask.

Note: Do not use suspect slings. Contact EnergySolutions Facility Manager if guidance is needed on a suspect sling condition.

Note: Shoring and bracing between the container and the cask is not required for close fitting containers.

4.9.8.2 Prior to installation of the primary cask lid for shipment, inspect the primary cask lid gasket and sealing surface for the following:

4.9.8.2.1 Gasket fully secured.

4.9.8.2.2 Gasket not cut, ripped or gouged.

4.9.8.2.3 Gasket is resilient.

4.9.8.2.4 Gasket is free of debris, dirt and/or grease.

4.9.8.2.5 Inspect gasket sealing surface of the cask for loose, chipped, or scratched painted surfaces which would affect proper sealing.

Note: Refer to Step 4.12 if gasket repair or replacement is required.

4.9.8.3 Inspect the gasket change data tag to ensure that the annual date of the primary and secondary cask lid gasket changes reflect compliance with Reference 2.3.

Note: If the gasket change data is found to be defective or missing, immediately notify EnergySolutions Facility Manager. Upon verification by EnergySolutions that the

gaskets are in compliance with Reference 2.3, the cask may be utilized.

- 4.9.8.4 Using the three (3) lifting lugs on the primary cask lid and suitable rigging, place primary cask lid on cask using alignment pins or alignment marks to ensure proper positioning. Take care to avoid gasket damage.

Note: Primary Cask Lid Weight (with secondary cask lid installed) is given in Attachment 5.3.

Note: Prior to use of rigging, verify its suitability for the load being lifted and that it has an up-to-date inspection/certification for use record. Contact EnergySolutions Facility Manager if guidance is needed.

- 4.9.8.5 Secure the primary cask lid to the cask. Perform Section 4.9.8.6 if the primary cask lid hold-down mechanisms are bolts/nuts or Section 4.9.8.7 if the primary cask lid hold-down mechanisms are ratchet binders.

Note: Attachment 5.3 gives the specific hold-down mechanism information applicable to the cask.

- 4.9.8.6 Secure primary lid using bolts/nuts as follows:

4.9.8.6.1 Check all stud threads, interior threads or hold-down bolts/nuts and the area on lid around studs for imperfection, galling, or other damage. Clean and re-coat with anti-seize compound as necessary.

4.9.8.6.2 Install and tighten the hold-down bolts/nuts in accordance with Attachment 5.3.

4.9.8.6.3 Proceed to Step 4.9.8.8.

Note: Check the clearance between the primary cask lid and the cask body at each 90° to ensure uniform seating.

- 4.9.8.7 Secure primary cask lid using ratchet binders as follows:

- 4.9.8.7.1 Install each threadless bolt through the upper ratchet binder connector and the lid closure lug (see Figure 4.1).
- 4.9.8.7.2 Install each retaining/lock pin through the hole in the threadless bolt.
- 4.9.8.7.3 Tighten each ratchet binder by engaging the flip block to the sprocket wheel and rotating the ratchet binder. Pull the handle away from the cask in the direction of tightening.

Caution: Ratchet binder handle rotation can become tight when loosening or tightening a ratchet binder. Therefore, visual inspection is necessary to ensure that the ends of the ratchet binder are moving together when the handle is rotated to tighten the primary lid. Ensure that all ratchet binders are equally tensioned as tightly as can be achieved without the use of mechanical aids (such as “cheater bars” or ratchet handle extensions).

- 4.9.8.7.4 Tighten ratchet binders so lid is snug against gasket without compressing it. The sequence of tightening the binders is specified in Attachment 5.3.
- 4.9.8.7.5 Once all binders are snug, they are to be torqued using a ratchet binder torque adapter provided with the cask. The binders are to be torqued as follows, using the same tightening sequence specified in Attachment 5.3.
 - Slide the ratchet binder torque adapter over the end of the ratchet binder handle until it can be slid no further. Install torque adapter lock pin (if provided).
 - Using Attachment 5.3 information, calculate the maximum and minimum torque wrench settings or dial readings required by

substituting the cask specific required torque value and wrench lengths in the equation given in Attachment 5.3.

- Torque the ratchet binder to the wrench setting or dial readings calculated in Attachment 5.3.

- 4.9.8.7.6 Visually inspect the primary cask lid to verify uniformity of closure.
- 4.9.8.7.7 Disengage each flip block and rotate and secure the handle to its storage position and install lock pin.
- 4.9.8.7.8 Install the three (3) primary cask lid lifting covers.
- 4.9.8.7.9 Install a shipping security seal through ratchet binder handles. In addition to this security seal, the cask user has the option to place a security seal on another ratchet binder located on the opposite side of the cask.

Note: Additional security seals added by entities other than EnergySolutions Engineering & Licensing shall not alter cask (e.g. drilling new holes in brackets or ratchet binder handles).

- 4.9.8.8 Remove the secondary cask lid hold-down bolts/nuts.
- 4.9.8.9 Remove the secondary cask lid lifting lug cover.
- 4.9.8.10 Using the secondary cask lid lifting lug(s), suitable rigging, and exercising caution due to possible contamination of the underside of the secondary cask lid, remove the secondary cask lid.

Note: Secondary Cask Lid Weight is given in Attachment 5.3.

Note: Prior to use of rigging, verify its suitability for the load being lifted and that it has an up-to-date inspection/certification for use record. Contact

EnergySolutions Facility Manager if guidance is needed.

Note: Care shall be exercised to prevent physical damage to the lid (e.g. bracing/blocking, cushioning).

4.9.8.11 Load the waste into the container through the secondary cask lid opening. Once loading is complete, in a manner consistent with ALARA (and good contamination control practices), inspect the cask cavity for foreign matter (e.g. water, solids) and remove if present.

Note: The total weight of the waste loading, container (including lid, plugs, caps, or other attachments) shoring, shieldings, and any other items present in the cask cavity after the cask is closed and ready for shipment must not exceed the payload limit given in Attachment 5.3.

4.9.8.12 Install the container lid, plugs or caps onto the container in accordance with container closure procedures.

4.9.8.13 Prior to installation of the secondary cask lid, inspect the secondary cask lid gasket and sealing surface for the following:

4.9.8.13.1 Gasket fully secured to the primary cask lid.

4.9.8.13.2 Gasket not cut, ripped or gouged.

4.9.8.13.3 Gasket is resilient

4.9.8.13.4 Gasket is free of debris, dirt and/or grease.

4.9.8.13.5 Inspect hold-down studs for thread imperfection, galling, or other damage.

4.9.8.13.6 Inspect lid hold-down flat-washers (if present) for damage. Replace if necessary.

4.9.8.13.7 Inspect the lid hold-down nuts for damage, gouges, or thread damage. Replace if damage is found.

4.9.8.13.8 Inspect the gasket sealing surface for loose, chipped, or scratched painted surfaces which would affect proper sealing.

Note: Refer to Step 4.12 if gasket maintenance or replacement is required.

4.9.8.14 Inspect the gasket change data tag to ensure that the date of the primary and secondary cask lid gasket changes reflect compliance with the requirements of Reference 2.3.

Note: If the gasket change data tag is found to be defective or missing, immediately notify EnergySolutions Facility Manager. Upon verification by EnergySolutions that the gaskets are in compliance with Reference 2.3, the cask may be utilized.

4.9.8.15 Using the secondary cask lid lifting lug and suitable rigging, lift and place lid into the opening on the primary cask lid. Use the alignment pins or alignment marks to ensure proper positioning. Take care not to damage gasket.

Note: Secondary Cask Lid Weight is given in Attachment 5.3.

Note: Prior to use of rigging, verify its suitability for the load being lifted and that it has an up-to-date inspection/certification for use record. Contact EnergySolutions Facility Manager if guidance is needed.

4.9.8.16 Ensure that all threaded surfaces and seating areas are coated with an anti-seize compound. Tighten the secondary cask lid stud nuts hand tight following the sequence given in Attachment 5.3.

4.9.8.17 Tighten each nut in sequence given in Attachment 5.3 until each has been torqued to the value specified in Attachment 5.3.

4.9.8.18 Install shipping security seals on the secondary lid through the hole provided in one of the secondary lid stud nuts.

Note: Cask must be properly sealed prior to shipment. Additional security seals added by entities other than EnergySolutions Engineering & Licensing shall not alter cask (e.g. drilling new holes in brackets or ratchet binder handles).

4.9.8.19 Proceed to Step 4.10.

4.9.9 Loading a Preprocessed Container into the Cask

Note: Review Suggested Pre-Release Checklist (Attachment 5.1) or similar site document and the shipping papers to ensure that required inspections are performed during the cask loading process and that information required on the shipping papers is determined.

Note: The total weight of all items placed inside the cask must not exceed the payload limit given in Attachment 5.3.

4.9.9.1 Ensure that the container lid, plugs or caps are installed on the container.

4.9.9.2 Inspect container lifting device (e.g. slings, cables, grapple) for damage or wear. Using the lifting device, place the container into the cask.

Note: Cask Payload Weight Limit is given in Attachment 5.3.

Note: Do not use suspect lifting device(s). Contact EnergySolutions Facility Manager if guidance is needed on a suspect lifting device(s) condition.

Note: Shoring and bracing between the container and cask is not required for close fitting containers.

4.9.9.3 Install the primary cask lid in accordance with Steps 4.9.8.2 through 4.9.8.5.

Note: Cask must be properly sealed prior to shipment. Additional security seals added by entities other than EnergySolutions Engineering & Licensing shall not alter cask (e.g. drilling new holes in brackets or ratchet binder handles).

4.10 Preparing the Cask and Vehicle for Shipment

Note: Contact EnergySolutions Engineering & Licensing before cask is returned to trailer.

4.10.1 If cask was removed from trailer, proceed as follows:

4.10.1.1 Using the cask lifting lugs (Note: the 10-142A cask is lifted utilizing three (3) cask primary lid lifting lugs) and suitable rigging, lift cask and place cask in proper position on trailer. Alignment marks, if present, should be used to ensure proper orientation on trailer.

Note: Prior to use of rigging, verify its suitability for the load being lifted and that it has an up-to-date inspection/certification for use record. Contact EnergySolutions Facility Manager if guidance is needed.

4.10.1.2 Inspect tie-down lugs and shackles on cask and transport trailer for cracks and wear which would affect their strength.

4.10.1.3 Inspect cask trailer tie-down cables to ensure they are not loose or damaged (crimped, frayed, etc.).

4.10.1.4 Inspect cask cable tie-down ratchets/turnbuckles to ensure they are in proper working condition.

4.10.1.5 Install a shackle through the end of each tie-down cable and attach to cask tie-down lug by screwing pin through shackle and hole in lug.

4.10.1.6 Tighten tie-down ratchets/turnbuckles as necessary to secure cask on trailer.

Note: Do not use a cheater bar to tighten binders or turnbuckles. Go to Attachment 5.3 for torque values for casks that use bolted connections for cask tie downs.

4.10.2 Ensure that the primary cask lid, secondary cask lid, and cask lifting lugs are covered for transit. For casks equipped with impact limiters, go to Attachment 5.2, Impact Limiter Handling and perform steps under Attachment 5.2 before continuing.

4.10.3 Ensure all security seals are installed and intact.

Note: For casks with an operational drain or vent port plug, if the drain or vent port has been used, or if its security seal has been disturbed, the plug shall be removed, reinstalled with a pipe joint sealing compound, and torqued to 25 ft-lbs (± 2). A new security seal shall then be installed.

4.10.4 Survey the loaded cask to ensure compliance with receiving facility requirements and the criteria in Step 4.1.1. Inspect for surface contamination per the site release requirements and criteria in Step 4.3. Complete the necessary shipping papers, certifications, and Attachment 5.1, or site equivalent.

4.10.5 If the cask is equipped with a rain-cover, install rain-cover.

4.10.6 Placard vehicle and label cask as necessary.

4.10.7 Recheck all cask tie-down devices for proper security.

4.11 Loaded Cask Receipt Inspection and Payload Unloading

4.11.1 Survey the cask and trailer in accordance with applicable site requirements and criteria given in Step 4.3.

4.11.2 Perform an external inspection of the unopened cask. Record any significant or potentially significant observations.

4.11.3 If cask is equipped with a rain-cover, remove it.

4.11.4 Ensure that cask lid (primary cask lid and secondary cask lid) lifting lug covers are with the cask.

4.11.5 Remove the primary cask lid in accordance with Step 4.7 of this procedure.

4.11.6 Exercising caution in accordance with ALARA, connect slings from the container or pallet to a suitable lifting device. To the extent feasible and consistent with ALARA, inspect the slings for damage or wear.

Note: Prior to use of rigging, verify its suitability for the load being lifted and that it has an up-to-date inspection/certification for use record. Contact EnergySolutions Facility Manager if guidance is needed.

Note: Do not use suspect slings. Contact EnergySolutions Facility Manager if guidance is needed on a suspect sling condition.

4.11.7 Exercising caution in accordance with ALARA, lift the payload (e.g. container or pallet) clear of the cask and place in site assigned location.

Note: Care should be taken to avoid damage to primary cask lid gasket.

4.11.8 Repeat Steps 4.11.6 and 4.11.7 for second pallet, if applicable.

4.11.9 After unloading the cask, the interior and exterior shall be visually inspected to ensure that they have not been significantly damaged (i.e. no cracks, punctures, holes, or broken welds). Inspect for water and foreign material and remove if present. Also, perform the following configuration checks after unloading and prior to any loading activity:

4.11.9.1 Exterior nameplates, stencils, placards and other required identification is in place and legible.

4.11.9.2 Ratchet binders, bolts, stud nuts, threadless bolts, and gaskets are in place, in good condition and free of defects.

4.11.9.3 All required documentation is completed and retained/displayed as required by the regulatory authority and the user.

Note: If significant damage is found, immediately notify EnergySolutions Facility Manager.

4.11.10 Place empty pallets, if applicable, back inside the cask unless instructed otherwise by EnergySolutions. Make sure all pallet slings are positioned to avoid damage.

4.11.11 Install cask lid in accordance with Steps 4.9.8.2 through 4.9.8.5.

4.11.12 Install the cask lid (primary cask lid and secondary cask lid) lifting lug covers. For casks equipped with impact limiters, perform steps in Attachment 5.2 before continuing.

4.11.13 Ensure all security seals are installed and intact.

Note: For casks with a drain or vent port plug, if the drain or vent port has been used, or if its security seal has been disturbed, the plug shall be removed, reinstalled with a pipe joint sealing compound, and torqued to 25 ft-lbs (± 2). A new security seal shall then be installed.

4.11.14 Survey the cask and trailer for release in accordance with applicable site requirements.

4.11.15 If cask is equipped with rain-cover, install cover.

4.12 Gasket Maintenance and Replacement Procedure

Perform gasket maintenance in accordance with Reference 2.9.

5. ATTACHMENTS

5.1 Suggested Pre-Release Checklist

5.2 Impact Limiter Handling

5.3 Cask Specific Weight and Torquing Information

**Attachment 5.1
Suggested Pre-Release Checklist**

Date	_____	Location	_____
Model No	_____	Cask Serial Number	_____
Shipment No	_____	Trailer No	_____
Transport No	_____		
Time/Date of Arrival	_____	Time/Date of Departure	_____

Item	Description	Initials
1	Inner container(s) sealed (i.e. lids, vents installed).	_____
2	Inner container(s) secured in place.	_____
3	No free standing water, obstructions, or significant damage in cask interior.	_____
4	No significant damage to cask exterior.	_____
5	All gaskets and gasket sealing surfaces inspected and satisfactory for use.	_____
6	Primary cask lid and/or secondary cask lid hold-down nuts/ratchet binders properly torqued.	_____
7	Drain and vent port plugs installed and properly torqued.	_____
8	Security seals installed and inspected. Primary Lid Seal #: _____ Vent Seal # _____ Secondary Ld Seal # _____ Drain Seal # _____	_____
9	Lifting lug covers installed.	_____
10	Impact limiters installed.	_____
11	Cask tie-downs inspected. Ratchets/turnbuckles tightened. Cotter pins, lock wire or other appropriate retaining devices are installed and are functional/secure on bolts, studs, pins, etc.	_____
12	Cask properly labeled.	_____
13	Vehicle properly placarded.	_____
14	Surveys completed and recorded.	_____
15	Shipping papers properly completed and signed.	_____

Signature

Date

Title

Attachment 5.2 Impact Limiter Handling

1.0 The following handling steps apply to cask operations involving impact limiter handling.

1.1 Impact Limiter Removal

1.1.1 Disconnect and remove the impact limiter as follows:

1.1.1.1 Remove the eight spring clip pins from the upper impact limiter attachment tabs by pulling the pin out through the hole in the attachment tabs and primary attachment lugs.

1.1.1.2 Remove the impact limiter lifting lug covers.

1.1.1.3 Connect a suitable lifting cable to the three impact lifting lugs in the center ring of the impact limiter.

Note: Prior to use of rigging, verify its suitability for the load being lifted and that it has an up-to-date inspection/certification for use record. Contact EnergySolutions Facility Manager if guidance is needed.

1.1.1.4 Lift the impact limiter away from the cask.

- 10-142A Series I upper impact limiter weighs 3,000 lbs.*
- 10-142A Series II upper impact limiter weighs 5,200 lbs.*

* Cask weights are obtained from the cask Safety Analysis Report. Actual weights identified on individual components or as found, may vary due to the manufacturing tolerances.

Note: Care shall be exercised to prevent physical damage during the storage of the impact limiter (e.g., bracing/blocking/cushioning).

1.1.1.5 Return to main procedure Step 4.7.1.1.

1.2 Impact Limiter Installation

1.2.1 Install upper impact limiter as follows:

1.2.1.1 Connect suitable rigging to the upper impact limiter lifting lugs and position impact limiter above cask primary lid.

Note: Prior to use of rigging, verify its suitability for the load being lifted and that it has an up-to-date inspection/certification for use record. Contact EnergySolutions Facility Manager if guidance is needed.

1.2.1.2 Prior to lowering upper impact limiter onto primary lid, align index attachment tab with alignment index lug on cask primary lid.

1.2.1.3 Lower upper impact limiter onto cask primary lid.

1.2.1.4 Install the eight spring clip pins into the attachment tabs.

1.2.1.5 Disconnect lifting cables from upper impact limiter.

1.2.1.6 Install the impact limiter lifting lug covers.

1.2.1.7 Return to main procedure Step 4.10.2.

**Attachment 5.3
Cask Specific Weight and Torquing Information**
(page 1 of 14)

This attachment contains individualized, cask specific data. This presents the procedurally relevant information unique to each cask:

Page	Cask
2	6-80-2 Series
3	8-120A
4	10-142A Series I
5	10-142A Series II
6	14D-2.0
7	14-170 Series
8	14-190 Series
9	14-195
10	14-210 Series
11	14-215
12	21-300

This attachment gives the General Torquing Sequence to be used for tightening ratchet binders/bolts and nuts (page 13 of this attachment). It also gives the General Method for Determining Torque Wrench Values (page 14 of this attachment).

Attachment 5.3
Cask Specific Weight and Torquing Information
(page 2 of 14)

6-80-2 Series

Weight Data

Component	Approximate Weight (lbs.)*
	No Insert
Empty Cask (lids installed)	44,000
Payload Limit	7,500
Loaded Cask Limit (lids installed)	51,500

Primary Lid Torquing Requirements

The torquing sequence is given in the General Torquing Sequence on page 13 of this attachment.

$$\text{Final Primary Lid Torque} = 320 \pm 32 \text{ ft-lbs}^{**}$$

The final calculated torque value shall be achieved with a minimum of two (2) passes

Secondary Lid Torquing Requirements

The torquing sequence is given in the General Torquing Sequence on page 13 of this attachment.
Torque each location to the final torque value:

$$\text{Final Secondary Lid Torque} = 160 \pm 16 \text{ ft-lbs}^{**}$$

The final calculated torque value shall be achieved with a minimum of two (2) passes

* Cask weights are obtained from the cask Safety Analysis Report. Actual weights identified on individual components or as found, may vary due to the manufacturing tolerances.

** Torque values as displayed in Safety Analysis Report, however EnergySolutions Engineering & Licensing permits a $\pm 10\%$ value on nominal torque value.

Attachment 5.3
Cask Specific Weight and Torquing Information
(page 3 of 14)

8-120A

Weight Data

Component	Approximate Pounds (lbs.)*
Empty Cask (lid installed)	50,000
Primary Lid	7,000
Payload Limit (sum of all items in the cask cavity)	20,000
Loaded Cask Limit (lid installed)	70,000

Primary Lid Torquing Requirements

The torquing sequence is given in the General Torquing Sequence on page 13 of this attachment.

Final Torque Value = 420 ± 42 ft-lbs**

* Cask weights are obtained from the cask Safety Analysis Report. Actual weights identified on individual components or as found, may vary due to the manufacturing tolerances.

** Torque values as displayed in Safety Analysis Report, however EnergySolutions Engineering & Licensing permits a $\pm 10\%$ value on nominal torque value.

Attachment 5.3
Cask Specific Weight and Torquing Information
(page 4 of 14)

10-142A Series I

Weight Data

Component	Approximate Pounds (lbs.)*
Empty Cask (lids installed)	54,000
Upper Impact Limiter	3,000
Primary Lid (secondary lid installed)	7,000
Secondary Lid	1,750
Payload Limit (sum of all items in the cask cavity)	9,130
Loaded Cask Limit (lids installed)	64,000

Primary Lid Torquing Requirements

The torquing sequence is given in the General Torquing Sequence on page 13 of this attachment.

The equation in the General Method for Determining Torque Wrench Values on page 14 of this attachment is to be used

$$C = 100 \pm 10 \text{ ft-lbs}^{**}$$

to determine the torque wrench setting or dial reading D.

The final calculated torque value D shall be achieved with a minimum of two (2) passes (see page 14 of this attachment).

Secondary Lid Torquing Requirements

The torquing sequence is given in the General Torquing Sequence on page 13 of this attachment. Torque each location to the final torque value:

$$\text{Final Secondary Lid Torque} = 100 \pm 10 \text{ ft-lbs}^{**}$$

The final calculated torque value D shall be achieved with a minimum of two (2) passes (see page 14 of this attachment).

* Cask weights are obtained from the cask Safety Analysis Report. Actual weights identified on individual components or as found, may vary due to the manufacturing tolerances.

** Torque values as displayed in Safety Analysis Report, however EnergySolutions Engineering & Licensing permits a $\pm 10\%$ value on nominal torque value.

Attachment 5.3
Cask Specific Weight and Torquing Information
(page 5 of 14)

10-142A Series II

Weight Data

Component	Approximate Pounds (lbs.)*
Empty Cask (lids and impact limiters installed)	58,100
Upper Impact Limiter	5,200
Lower Impact Limiter	5,200
Primary Lid (secondary lid installed)	7,330
Secondary Lid	1,800
Payload Limit (sum of all items in the cask cavity)	10,000
Loaded Cask Limit (lids installed)	68,100

Primary Lid Torquing Requirements

The torquing sequence is given in the General Torquing Sequence on page 13 of this attachment.

The equation in the General Method for Determining Torque Wrench Values on page 14 of this attachment is to be used to determine the torque wrench setting or dial reading D.

- First Pass - Primary Lid: 150 ft.-lbs. (lubricated)
- Second Pass - Primary Lid : 250 ft.-lbs. (lubricated)
- Final Pass - Primary Lid: 300 ft.-lbs. \pm 25 ft.-lbs. **(lubricated)

Secondary Lid Torquing Requirements

The torquing sequence is given in the General Torquing Sequence on page 13 of this attachment. Torque each location to the final torque value:

- First Pass - Secondary Lid: 100 ft.-lbs. (lubricated)
- Second Pass - Secondary Lid: 170 ft.-lbs. (lubricated)
- Final Pass - Secondary Lid: 200 ft.-lbs. \pm 10 ft.-lbs.** (lubricated)

* Cask weights are obtained from the cask Safety Analysis Report. Actual weights identified on individual components or as found, may vary due to the manufacturing tolerances.

** Torque values as displayed in Safety Analysis Report, however EnergySolutions Engineering & Licensing permits a \pm 10 % value on nominal torque value.

Attachment 5.3
Cask Specific Weight and Torquing Information
(page 6 of 14)

14D-2.0

Weight Data

Component	Approximate Pounds (lbs.)*
Empty Cask (lids installed)	35,000
Upper Impact Limiter	3,000
Primary Lid	6,100
Secondary Lid	400
Payload Limit (sum of all items in the cask cavity)	14,000
Loaded Cask Limit (lids installed)	49,000

Primary Lid Torquing Requirements

The torquing sequence is given in the General Torquing Sequence on page 13 of this attachment.

The equation in the General Method for Determining Torque Wrench Values on page 14 of this attachment is to be used

$$C = 100 \pm 10 \text{ ft-lbs}^{**}$$

to determine the torque wrench setting or dial reading D.

The final calculated torque value D shall be achieved with a minimum of two (2) passes (see page 14 of this attachment).

Secondary Lid Torquing Requirements

The torquing sequence is given in the General Torquing Sequence on page 13 of this attachment. Torque each location to the final torque value:

$$\text{Final Secondary Lid Torque} = 100 \pm 10 \text{ ft-lbs}^{**}$$

The final calculated torque value D shall be achieved with a minimum of two (2) passes (see page 14 of this attachment).

* Cask weights are obtained from the cask Safety Analysis Report. Actual weights identified on individual components or as found, may vary due to the manufacturing tolerances.

** Torque values as displayed in Safety Analysis Report, however EnergySolutions Engineering & Licensing permits a $\pm 10\%$ value on nominal torque value.

Attachment 5.3
Cask Specific Weight and Torquing Information
(page 7 of 14)

14-170 Series

Weight Data

Component	Series II Approximate Pounds (lbs.)*	Series I & III Approximate Pounds (lbs.)*
Empty Cask (lids installed)	35,000	35,200
Primary Lid	6,100	6,170
Secondary Lid	400	370
Payload Limit (sum of all items in the cask cavity)	14,000	17,800
Loaded Cask Limit (lids installed)	49,000	53,000

Primary Lid Torquing Requirements (Series II)

The torquing sequence is given in the General Torquing Sequence on page 13 of this attachment. The equation in the General Method for Determining Torque Wrench Values on page 14 of this attachment is to be used

$C = 100 \pm 10$ ft-lbs**, to determine the torque wrench setting or dial reading D.

Secondary Lid Torquing Requirements (Series II)

The torquing sequence is given in the General Torquing Sequence on page 13 of this attachment. Torque each location to the final torque value:

$$\text{Final Secondary Lid Torque} = 100 \pm 10 \text{ ft-lbs**}$$

Primary Lid Torquing Requirements (Series I & III)

The torquing sequence is given in the General Torquing Sequence on page 13 of this attachment. The equation in the General Method for Determining Torque Wrench Values on page 14 of this attachment is to be used

$C = 175-200$ ft-lbs**, to determine the torque wrench setting or dial reading D.

Secondary Lid Torquing Requirements (Series I & III)

The torquing sequence is given in the General Torquing Sequence on page 13 of this attachment. Torque each location to the final torque value:

$$\text{Final Secondary Lid Torque} = 120 \pm 10 \text{ ft-lbs**}$$

* Cask weights are obtained from the cask Safety Analysis Report. Actual weights identified on individual components or as found, may vary due to the manufacturing tolerances.

** Torque values as displayed in Safety Analysis Report, however EnergySolutions Engineering & Licensing permits a $\pm 10\%$ value on nominal torque value.

Attachment 5.3
Cask Specific Weight and Torquing Information
(page 8 of 14)

14-190

Weight Data

Component	Approximate Pounds (lbs.)*
Empty Cask (lids installed)	45,200
Primary Lid (secondary lid installed)	7,650
Secondary Lid	1,150
Payload Limit (sum of all items in the cask cavity)	20,000
Loaded Cask Limit (lids installed)	65,200

Primary Lid Torquing Requirements

The torquing sequence is given in the General Torquing Sequence on page 13 of this attachment. The equation in the General Method for Determining Torque Wrench Values on page 14 of this attachment is to be used

$$C = 100 \pm 10 \text{ ft-lbs}^{**}$$

to determine the torque wrench setting or dial reading D.

The final calculated torque value D shall be achieved with a minimum of two (2) passes (see page 14 of this attachment).

Secondary Lid Torquing Requirements

The torquing sequence is given in the General Torquing Sequence on page 13 of this attachment. Torque each location to the final torque value:

$$\text{Final Secondary Lid Torque} = 100 \pm 10 \text{ ft-lbs}^{**}$$

The final calculated torque value D shall be achieved with a minimum of two (2) passes (see page 14 of this attachment).

* Cask weights are obtained from the cask Safety Analysis Report. Actual weights identified on individual components or as found, may vary due to the manufacturing tolerances.

** Torque values as displayed in Safety Analysis Report, however EnergySolutions Engineering & Licensing permits a $\pm 10\%$ value on nominal torque value.

Attachment 5.3
Cask Specific Weight and Torquing Information
(page 9 of 14)

14-195

Weight Data

Component	Approximate Weight (lbs.)*
	No Insert
Empty Cask (lids installed)	38,800
Primary Lid (With secondary lid Installed)	6,300
Secondary Lid Weight	850
Payload Limit	17,700
Loaded Cask Limit (lids installed)	56,500

Primary Lid Torquing Requirements

The torquing sequence is given in the General Torquing Sequence on page 13 of this attachment.

Final Primary Lid Torque = 200 ± 10 ft-lbs**

Secondary Lid Torquing Requirements

The torquing sequence is given in the General Torquing Sequence on page 13 of this attachment.
Torque each location to the final torque value:

Final Secondary Lid Torque = 50 ± 5 ft-lbs**

Cask Tie Down Bolt Torquing Requirements

- 1) Tighten all sixteen (16) cask base plate bolts to 100 ft-lbs
- 2) Torque each cask base plate bolt to 450 ± 45 ft-lbs. Tighten all four (4) bolts in one corner then tighten all four (4) bolts in the opposite corner. Repeat this for remaining corners.
- 3) Continue to torque bolts as described above until the proper torque value is achieved.

* Cask weights are obtained from the cask Safety Analysis Report. Actual weights identified on individual components or as found, may vary due to the manufacturing tolerances.

** Torque values as displayed in Safety Analysis Report, however EnergySolutions Engineering & Licensing permits a $\pm 10\%$ value on nominal torque value.

Attachment 5.3
Cask Specific Weight and Torquing Information
 (page 10 of 14)

14-210 Series

Weight Data

Component	Approximate Weight (lbs.)*	
	14-210L	14-210H
Empty Cask (lids installed)	31,600	38,400
Primary Lid (secondary lid installed)	7,700	7,700
Secondary Lid	2,000	2,000
Payload Limit (sum of all items in the cask cavity)	20,000	20,000
Loaded Cask Limit (lids installed)	51,600	58,400

Primary Lid Torquing Requirements

The torquing sequence is given in the General Torquing Sequence on page 13 of this attachment.

The equation in the General Method for Determining Torque Wrench Values on page 14 of this attachment is to be used

$C = 100 \pm 10$ ft-lbs**, to determine the torque wrench setting or dial reading D.

The final calculated torque value D shall be achieved with a minimum of two (2) passes (see page 14 of this attachment).

Secondary Lid Torquing Requirements

The torquing sequence is given in the General Torquing Sequence on page 13 of this attachment. Torque each location to the final torque value:

$$\text{Final Secondary Lid Torque} = 100 \pm 10 \text{ ft-lbs**}$$

The final calculated torque value D shall be achieved with a minimum of two (2) passes (see page 14 of this attachment).

* Cask weights are obtained from the cask Safety Analysis Report. Actual weights identified on individual components or as found, may vary due to the manufacturing tolerances.

** Torque values as displayed in Safety Analysis Report, however EnergySolutions Engineering & Licensing permits a $\pm 10\%$ value on nominal torque value.

Attachment 5.3
Cask Specific Weight and Torquing Information
 (page 11 of 14)

14-215

Weight Data

Component	Approximate Weight (lbs.)*		
	No Insert	w/1" Insert	w/1¼" Insert
Empty Cask (lids installed)	38,400	43,600	45,000
Primary Lid (secondary lid installed)	7,700	7,700	7,700
Secondary Lid	2,000	2,000	2,000
Payload Limit (sum of all items in the cask cavity)	20,000	14,800***	13,400***
Loaded Cask Limit (lids installed)	58,400	58,400	58,400

Primary Lid Torquing Requirements

The torquing sequence is given in the General Torquing Sequence on page 13 of this attachment.

The equation in the General Method for Determining Torque Wrench Values on page 14 of this attachment is to be used with:

$C = 100 \pm 10$ ft-lbs**, to determine the torque wrench setting or dial reading D.

The final calculated torque value D shall be achieved with a minimum of two (2) passes (see page 14 of this attachment).

Secondary Lid Torquing Requirements

The torquing sequence is given in the General Torquing Sequence on page 13 of this attachment. Torque each location to the final torque value:

$$\text{Final Secondary Lid Torque} = 100 \pm 10 \text{ ft-lbs}^{**}$$

The final calculated torque value D shall be achieved with a minimum of two (2) passes (see page 14 of this attachment).

* Cask weights are obtained from the cask Safety Analysis Report. Actual weights identified on individual components or as found, may vary due to the manufacturing tolerances.

** Torque values as displayed in Safety Analysis Report, however EnergySolutions Engineering & Licensing permits a $\pm 10\%$ value on nominal torque value.

*** Payload weight reduced due to weight of shield insert.

Attachment 5.3
Cask Specific Weight and Torquing Information
(page 12 of 14)

21-300

Weight Data

Component	Approximate Weight (lbs.)*
	No Insert
Empty Cask (lids installed)	30,200
Primary Lid (With secondary lid Installed)	4,000
Secondary Lid Weight	850
Payload Limit	27,250
Loaded Cask Limit (lids installed)	57,450

Primary Lid Torquing Requirements

The torquing sequence is given in the General Torquing Sequence on page 13 of this attachment.

Final Primary Lid Torque = 200 ± 10 ft-lbs**

Secondary Lid Torquing Requirements

The torquing sequence is given in the General Torquing Sequence on page 13 of this attachment.
Torque each location to the final torque value:

Final Secondary Lid Torque = 50 ± 5 ft-lbs**

Cask Tie Down Bolt Torquing Requirements

- 1) Tighten all sixteen (16) cask base plate bolts to 100 ft-lbs
- 2) Torque each cask base plate bolt to 450 ± 45 ft-lbs. Tighten all four (4) bolts in one corner then tighten all four (4) bolts in the opposite corner. Repeat this for remaining corners.
- 3) Continue to torque bolts as described above until the proper torque value is achieved.

* Cask weights are obtained from the cask Safety Analysis Report. Actual weights identified on individual components or as found, may vary due to the manufacturing tolerances.

** Torque values as displayed in Safety Analysis Report, however EnergySolutions Engineering & Licensing permits a $\pm 10\%$ value on nominal torque value.

Attachment 5.3
Cask Specific Weight and Torquing Information
(page 13 of 14)

General Torquing Sequence

The proper torquing of lid fasteners on the cask is the responsibility of the equipment user. The lid fastener installation and torquing sequence shall be accomplished in accordance with the following.

The load tightening and torquing sequence shall be consistent with the sequence shown in Figure 3. If more than eight (8) torquing locations are involved, tighten the remaining locations by opposite pair progression around the cask.

Figure 3: Torquing Sequence

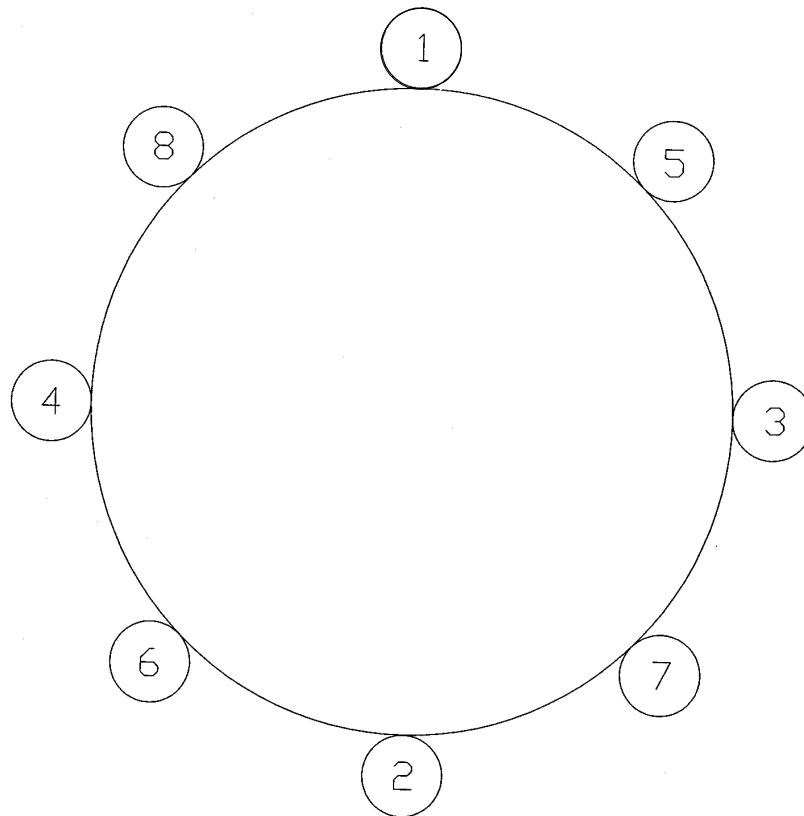

Attachment 5.3
Cask Specific Weight and Torquing Information
 (page 14 of 14)

General Method for Determining Torque Wrench Values

Determine the required torque wrench reading D to attain the required ratchet binder torque value “C” using the following formula:

$$D = \frac{B}{A+B} \times C$$

- A = Length from center line of the torque wrench adapter ½” drive socket to the center line of the ratchet binder retaining screw (see Figure 4)
- B = Length of torque wrench from center line of ½ drive to the center of the grip area (see Figure 4)
- C = Required torque for the applicable ratchet binder (see applicable Cask Weight and Torquing Sheet or Table 1)
- D = Calculated final setting or reading of the torque wrench required to attain “C”

The measurement points for determining the A and B parameters in the above equation are shown in Figure 4. The required cask primary lid torque for the applicable ratchet binder is given in applicable Cask Weight and Torquing Sheet or Table 1.

As an example (refer to Table 4), using a torque wrench with measured length (B) of 18” from ½” drive socket to center of gripper, a measured length (A) of 12” from the centerline of the torque wrench adapter ½” drive socket installed on the handle to the centerline of the ratchet binder retaining screw, and a required torque reading of 100 ft-lbs.

$$D = \frac{18}{18+12} \times 100 \text{ ft-lbs} = 60 \text{ ft-lbs} = \text{calculated final torque reading to attain "C"}$$

Range = 60 ±10 % = 54 to 66 ft-lbs

The applicable Cask Weight and Torquing Sheet or Table 1 lists the required ratchet binder/bolt torque values for the various DOT-7A, Type A casks.

Table 1: Required Ratchet Binder/Bolt Torque Values

Cask	Required Torque C (ft-lbs)*	
	Primary Lid	Secondary Lid
6-80-2	320 ± 32	160 ± 16
8-120A	420 ± 42	N/A
10-142A Series I	100 ± 10	100 ± 10
10-142A Series II	150 / 250 / 300 ± 25	100 / 170 / 200 ± 10
14D-2.0	100 ± 10	100 ± 10
14-170 II	100 ± 10	100 ± 10
14-170 I & III	175-200	120 ± 10
14-190	100 ± 10	100 ± 10
14-195	200 ± 10	50 ± 5
14-210 Series	100 ± 10	100 ± 10
14-215	100 ± 10	100 ± 10
21-300	200 ± 10	50 ± 5

* Torque values as displayed in SAR report, however EnergySolutions Engineering & Licensing permits a ± 10 % value on nominal torque value for casks listed in Table 1.

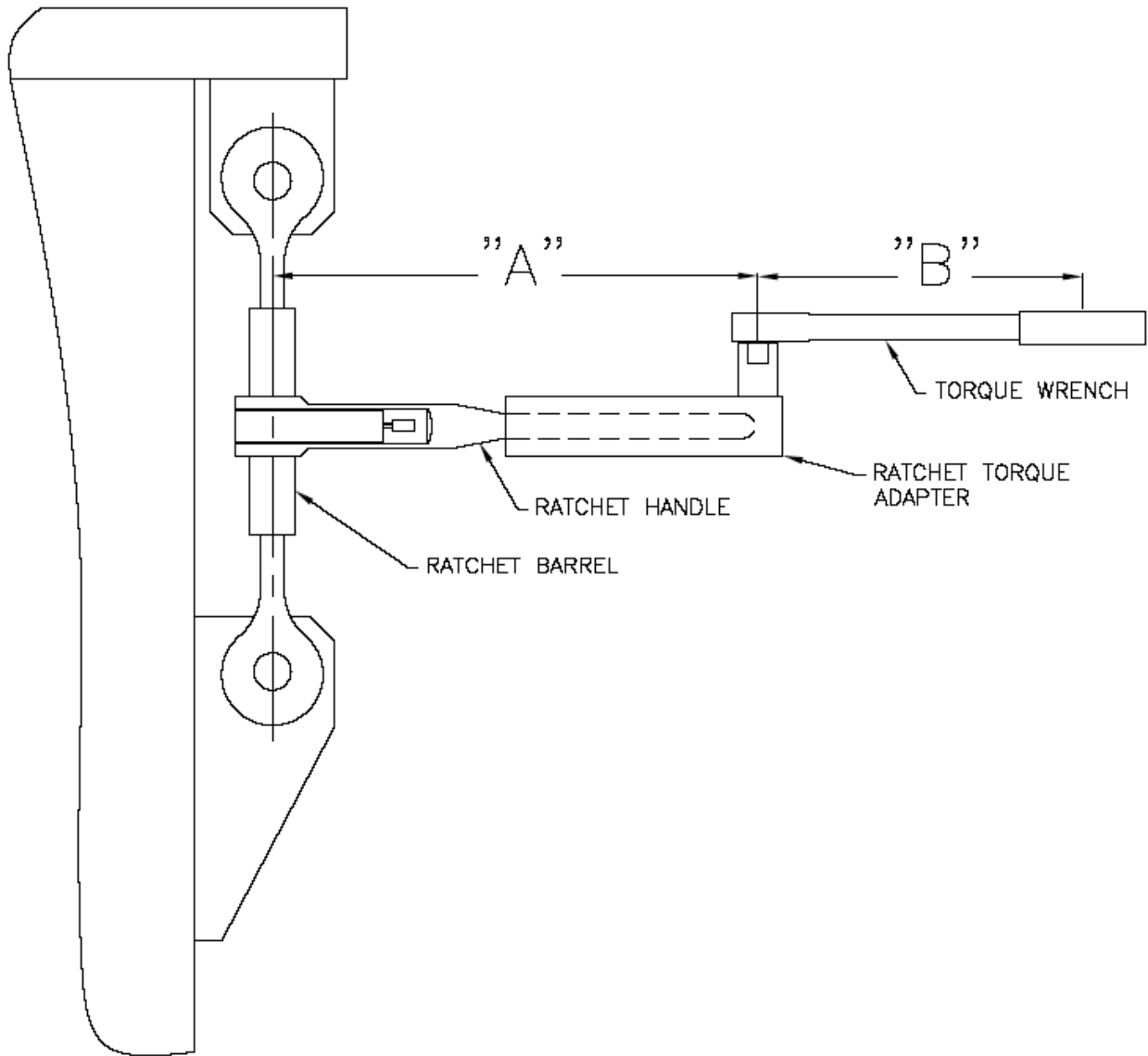
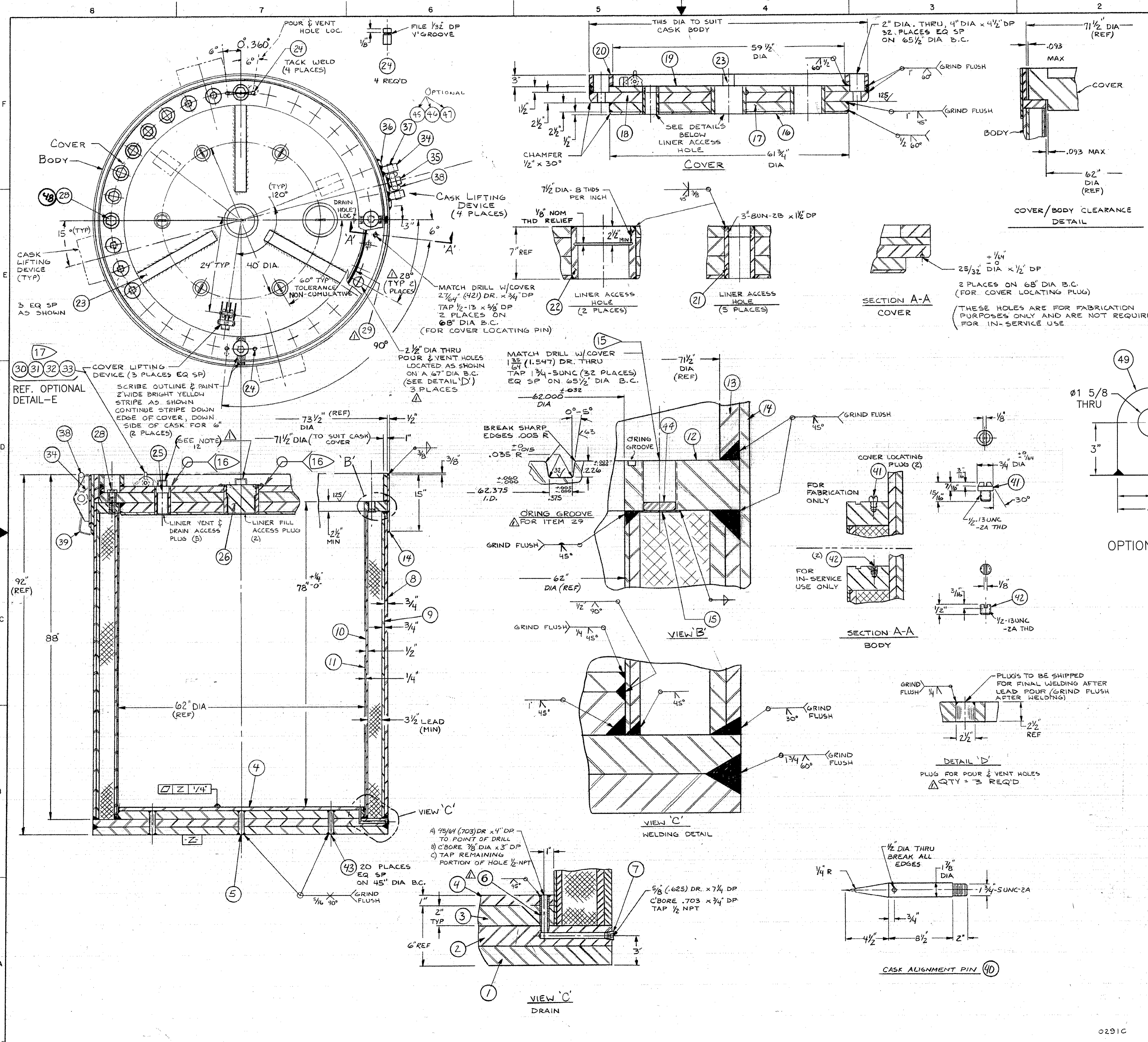

Figure 4: Illustration of Torque Configuration for Type A Casks

Section 3

Drawings



REV	DESCRIPTION	APPROVED
1	REVISED NOTE 5 ADDED NOTE 12 ADDED ITEM 29 CALLOUT 2 PLACES (40) 3 PLACES (40) SEE NOTE 12 (19) FOR ITEM 29 (5), ITEM 6 CALLOUT (68), QTY 3 REQ'D (36) SEE ECO 29008-1-002	

FOR GENERAL NOTES AND BILL OF MATERIAL SEE #29008-1 SHT 2 A

	CHEM-NUCLEAR SYSTEMS, INC. 8-120 A CASK 29008-1-6
--	--

0291C

GENERAL NOTES

- 1) **MATERIAL:** UNLESS OTHERWISE NOTED, OR CHEM-NUCLEAR APPROVED EQUIVALENT
 - (A) CARBON STEEL
 - PLATES - ASTM A-300, A-516 GRADE 60
 - RODS & BOLTS - ASTM A-320 GRADE L7
 - (B) LEAD - PIG LEAD, CHEMICAL GRADE ASTM B29-55 (1966 REAPPROVAL)
- 2) **WELDING:** ALL WELDS TO BE COMPLETE PENETRATION, UNLESS OTHERWISE NOTED. USE ELECTRODE ASTM A-316, CLASS E8016-C3. SEAM WELDS ON INNER & OUTER SHELLS TO BE STAGGERED & GROUND FLUSH. WELDS, WELDERS & INSPECTION OF CASKS STRUCTURAL INTEGRITY SHALL CONFORM TO ASME SECTION III, CLASS C.
- 3) **PAINT PREPARATION:** PRIOR TO PAINT APPLICATION, REMOVE ALL GREASE, OIL, SALT, CHEMICALS & SIMILAR CONTAMINANTS IN ACCORDANCE WITH SSPC-SP 1 (SOLVENT CLEANING). THE SURFACE SHALL THEN BE DRY ABRASIVE BLAST CLEANED IN ACCORDANCE WITH SSPC-SP6 (COMMERCIAL BLAST CLEANING) USING ABRASIVE OR SUCH PARTICLE SIZE AS TO GIVE AN ANCHOR PROFILE OF 1.5 MILS. PRIOR TO PAINTING, BLAST MEDIA RESIDUE SHALL BE REMOVED BY AIR BLASTING OR VACUUM CLEANING. THE PRIMER SHALL BE APPLIED WITHIN 8 HOURS AFTER BLAST CLEANING OR BEFORE ANY VISIBLE RUSTING OCCURS.
- 4) **PAINT PROCEDURE:** PAINT PER "CARBOLINE" SPEC 188 EPOXY PRIMER & PAINT SYSTEM. TOTAL MINIMUM THICKNESS 6 MILS (EXCEPT MACHINED SURFACES).
- 5) (A) ± .032 TOLERANCE WITH RESPECT TO 2 1/2 THK FLANGE.
(B) ± 1/4 TOLERANCE WITH RESPECT TO INNER SHELL ASSEMBLY, (ITEM 10 & 11) LENGTH, 78 1/2".
- 6) **TOLERANCE:** UNLESS OTHERWISE SPECIFIED.
DIMENSIONS UNDER 12" ± 1/16
12" TO 24" ± 1/8
24" TO 60" ± 3/16
OVER 60" AS SPECIFIED
- 7) **LEAD INTEGRITY AND SHIELDING EFFECTIVENESS**
ALL LEAD POURING SHALL BE DONE CONTINUOUSLY TO AVOID GAPS OF RADIATION STREAMING PATHS. GAMMA SCAN OF PROBE WILL BE REQUIRED TO INSURE SHIELDING INTEGRITY. LOSS OF SHIELDING AT ANY POINT IN EXCESS OF 5% WILL REQUIRE REMEDY BY THE FABRICATOR. THE PROCEDURES AND EQUIPMENT TO BE USED FOR THE LEAD POURING AND SUBSEQUENT TEST OF SHIELDING EFFECTIVENESS MUST BE APPROVED BY CHEM-NUCLEAR PRIOR TO PERFORMANCE.
- 8) INNER AND OUTER SHELL ASSEMBLIES 8/9 AND 10/11 MUST NOT BE CLEANED FREE OF MILL SCALE PRIOR TO WELDING AND A LOOSE FIT MUST BE MAINTAINED BY FITTING THESE SHELLS SUCH THAT THERE IS A 1/32 RADIAL GAP.
- 9) THE CAVITY WHICH WILL ACCOMMODATE THE LEAD POUR MUST BE WIRE BRUSH CLEANED FREE FROM RUST AND MILL SCALE. OIL AND GREASE MUST BE REMOVED BY A SUITABLE SOLVENT TO MAINTAIN ALL SURFACES CLEAN PRIOR TO LEAD POUR.
- 10) LEAK TEST: ALL WELDS ARE TO BE TESTED USING A DYE PENETRANT METHOD. THE ASSEMBLED CASK, WITH ALL SEALS IN PLACE IS TO BE LEAK TESTED ACCORDING TO ASME CODE SECTION VIII, TO INSURE ITS INTEGRITY. THE NORMAL OPERATING PRESSURE OF THE INTERNAL CAVITY IS 8.7 PSIG.
- 11) AFTER EACH USE: PRIOR TO INSERTING PLUGS, COAT THREADS WITH NON-HARDENING THREAD SEALANT.
SUGGESTED SEALANTS:

PERMATEX #2	BY PERMATEX CO., INC.
PLASTIC -SEAL	BY JOHNS-MANVILLE
KEY PASTE	BY W. K. M. VALVE
QUIGLEY "Q" SEAL	BY ZOPHAR MILLS
OR CHEM-NUCLEAR APPROVED EQUIVALENT	
- 12) A) THE HANDLE ON THE LINER FILL ACCESS PLUG (ITEM 26) MAY BE REPLACED WITH A 1 1/2" SQUARE BY 1" HIGH BAR STOCK ATTACHED TO THE PLUG WITH A 1/4" FILLET WELD.
B) THE HANDLE ON THE LINER VENT AND DRAIN ACCESS PLUG (ITEM 25) MAY BE REPLACED WITH 1 1/2" SQUARE BY 1 1/4" HIGH BAR STOCK ATTACHED TO THE PLUG WITH A 1/4" FILLET WELD.
- 13) OPTION: CASKS FITTED WITH ITEM 44, WILL USE A 1 3/4 - 5 UNC x 4 1/2" LG. BOLT, HEX HEAD OR SOCKET HEAD, ASTM A320 GR. L7 OR EQUAL. ITEM 44 MAY BE INSTALLED WITH LOCKTITE NO. 262.
(NOTE: - ITEM 44 MAY HAVE A SCREWDRIVER SLOT IN ONE SIDE FOR THREADING INTO HOLE. - PLUG MUST CLEAR WELD OF ITEM 15 TO ITEM 12 AT BOTTOM OF HOLE TO SIT FLUSH.)

17) OPTIONAL LUG (ITEM 49) MAY BE USED IN PLACE OF ITEMS 30, 31, 32, 33.

14) OPTIONAL

15) THE USE OF THREADED INSERTS IS OPTIONAL WITH ENERGYSOLUTIONS APPROVAL. THE INSERTS MUST HAVE A MINIMUM TENSILE STRENGTH OF 150,000 PSI. INSERT MATERIAL SHALL BE 304 STAINLESS, INCONEL X750 OR NITRONIC 60. REFER TO SECTION 8.2.6 OF THE SAR FOR REQUIRED INSPECTION AND TESTING.

16) SEAL WELD IN ACCORDANCE WITH THE JOINT GEOMETRY TOP AND BOTTOM OF PLUG. NON STRUCTURAL WELD.

BILL OF MATERIALS			
ITEM	QTY	DESCRIPTION (ALL DIM. NOMINAL)	SPEC. AND / OR PART No.
1	1	PLATE 2" THK. X 73 1/2" DIA.	ASTM A300, A516 GR. 60
2	1	PLATE 2" THK. X 73 1/2" DIA.	ASTM A300, A516 GR. 60
3	1	PLATE 2" THK. X 62" DIA.	ASTM A300, A516 GR. 60
4	1	PLATE 1" THK. X 62" DIA.	ASTM A300, A516 GR. 60
5	1	ROD 1 1/2" DIA. X 5 7/8" LG.	ASTM A320, GR. L7
6	1	PIPE - 1/2" STD. X 3 3/4" LG.	ASTM A36
7	1	PIPE PLUG - 1/2" STD., C' SUNK, SQ. PATTERN	
8	1	PLATE ROLLED - 3/4" THK. X 78 1/2" LG. X 72" I.D.	ASTM A300, A516 GR. 60
9	1	PLATE ROLLED - 3/4" THK. X 78 1/2" LG. X 70 1/2" I.D.	ASTM A300, A516 GR. 60
10	1	PLATE ROLLED - 1/2" THK. X 78 1/2" X 62 1/2" I.D.	ASTM A300, A516 GR. 60
11	1	PLATE ROLLED - 1/4" THK. X 78 1/2" X 62" I.D.	ASTM A300, A516 GR. 60
12	1	PLATE 2 1/2" THK. 62" I.D. X 73 1/2" O.D.	ASTM A300, A516 GR. 60
13	1	PLATE ROLLED - 1" THK. X 71 1/2" I.D. X 7"	ASTM A300, A516 GR. 60
14	1	PLATE ROLLED - 1/2" THK. X 15" X 73 1/2" I.D.	ASTM A300, A516 GR. 60
15	1	SHEET 1/16" THK. 63 1/2" I.D. X 67 1/2" O.D.	ASTM A36
16	1	PLATE 1/2" THK. X 61 3/4" O.D.	ASTM A300, A516 GR. 60
17	1	PLATE 2 1/2" THK. X 61 3/4" O.D.	ASTM A300, A516 GR. 60
18	1	PLATE 2 1/2" THK. X 71 1/2" O.D.	ASTM A300, A516 GR. 60
19	1	PLATE 1 1/2" THK. X 71 1/2" O.D.	ASTM A300, A516 GR. 60
20	1	PLATE 3" THK. X 59 1/2" I.D. X 71 1/2" NOM. O.D.	ASTM A300, A516 GR. 60
21	5	PIPE - 3 1/2" DOUBLE EXTRA STRONG X 7" LG.	ASTM A333, GR 10R6
22	2	PIPE - 8" DOUBLE EXTRA STRONG X (150W) X 7" LG.	ASTM A333, GR 10R6
23	3	BAR 3" X 3" X 22" LG.	ASTM A36
24	4	ROD 1/4" DIA. X 1/2" LG.	ASTM A36
25	5	ROD 3" DIA. X 7" LG.	ASTM A36
26	2	ROD 6.83" DIA. X 7 1/8" LG. RING 10 5/8 DIA. X 3/8 THK.	ASTM A36
27		DELETED	
28	32	BOLT 1 3/4 - 5 UNC X 4 7/8" LG. HEX HD OR SOCKET HD	ASTM A320 GR L7 OR EQ
29	1	O-RING 62 3/8 I.D. X 5/16" THK	SILICONE
30	12	PLATE 6" X 2 11/16" X 1/4" THK.	ASTM A285-C PVQ
31	3	PLATE 1/16" THK.	ASTM A285-C PVQ
32	3	ROD 7/8" DIA. X 4" LG.	ASTM A193 GR. B7
33	3	SHACKLE 3/4 ROUND PIN CHAIN TYPE	# S-215 CROSBY OR EQ.
34	8	PLATE 4 1/4 X 11 1/2 X 1" THK.	ASTM A285-C PVQ
35	4	PLATE 3 5/8 X 7 1/2 X 1" THK.	ASTM A285-C PVQ
36	4	PLATE 12 1/4 X 13 X 5/8" THK.	ASTM A285-C PVQ
37	4	ROD 1 1/2" DIA. X 9 3/4" LG.	ASTM A193 GR. B7
38	4	SHACKLE 1 3/8" ROUND PIN - CHAIN TYPE	# S-215 CROSBY OR EQ.
39	4	PLATE 1/16" THK.	ASTM A285-C PVQ
40	2	BAR 1 7/8" DIA. X 15" LG.	ASTM 1020
41	2	BAR 3/4" DIA. X 15/16"	ASTM A36
42	2	BAR 1/2" THD ROD X 1/2" LG.	ASTM A36
43	20	ROD 1 1/2" DIA. X 6" LG.	ASTM A320 GR L7
44	A/R	PLUG. 1 3/4 - 5 UNC THREAD X 3/8" (+0, -1/32") LG.	ASTM A36
45	4	ROD 1 1/2" DIA. X 12" LG. THREADED BOTH ENDS	ASTM A193 GR. B7
46	8	8, 1 1/2"-8 UN NUT	ASTM A194 GR 2H
47	8	3/16" x 2 1/2" LG. COTTER PIN	COMMERCIAL
48	32	1 3/4" FLAT WASHER, GR 8, C/S PLATED	COMMERCIAL
49	3	PLATE, 3/4" THK., 4" X 5"	ASTM A516 GR. 70

02926/0137V(c)

<table border="0"> <tr><td>DESIGNED</td><td>DATE</td><td>NO.</td></tr> <tr><td>CHECKED</td><td>DATE</td><td>NO.</td></tr> <tr><td>APPROVED</td><td>DATE</td><td>NO.</td></tr> </table>	DESIGNED	DATE	NO.	CHECKED	DATE	NO.	APPROVED	DATE	NO.	<table border="0"> <tr><td>DESCRIPTION</td><td>BY</td><td>APPR.</td></tr> <tr><td colspan="3">TITLE: BILL OF MATERIAL</td></tr> <tr><td colspan="3">8-120A CASK (2H)</td></tr> <tr><td>REVISION NUMBER</td><td>29008-1</td><td>REV 6</td></tr> </table>	DESCRIPTION	BY	APPR.	TITLE: BILL OF MATERIAL			8-120A CASK (2H)			REVISION NUMBER	29008-1	REV 6
DESIGNED	DATE	NO.																				
CHECKED	DATE	NO.																				
APPROVED	DATE	NO.																				
DESCRIPTION	BY	APPR.																				
TITLE: BILL OF MATERIAL																						
8-120A CASK (2H)																						
REVISION NUMBER	29008-1	REV 6																				

Section 4

Conformance with Specifications for Industrial Packaging Type 1 and Type 2

Approvals Page

**Conformance of CNS 8-120A Cask with Specifications for
Industrial Packaging Type 1 and Type 2**

Prepared by:	Signature on File	4/6/11
	Michael J. Frassica, Project Engineer	Date
Independent Reviewer:	Signature on File	4/7/11
	Matthew Zwicker, Project Engineer	Date

TABLE OF CONTENTS

1.0 INTRODUCTION.....	3
2.0 DISCUSSION.....	3
3.0 RESULTS.....	4
4.0 CONCLUSIONS AND RECOMMENDATIONS	14
5.0 REFERENCES.....	14

1.0 Introduction

This report evaluates the CNS 8-120A cask's conformance with 49CFR173.411 "Industrial Packagings" (Reference 5.1). This report fulfills the requirement of 49CFR173.411 for IP-2 packages as authorized packaging containing quantities not exceeding A_1 or A_2 which specifies that:

Except for IP-1 packages, each offeror of an industrial package must maintain on file for at least one year after the latest shipment, and shall provide to the Associate Administrator on request, complete documentation of tests and an engineering evaluation or comparative data showing that the construction methods, packaging design, and materials of construction comply with that specification.

2.0 Discussion

The CNS 8-120A was initially certified through licensing by the US NRC under Certificate of Compliance USA\6601A. This license expired on April 1, 1999 as a consequence of regulatory changes that result in the NRC no longer licensing Type A packages. The CNS 8-120A was certified as a Type A package by demonstrating compliance with NRC Type A requirements, including 10CFR71.43, "General Standards for All Packages," and 10CFR71.71, "Normal Conditions of Transport." Therefore, the CNS 8-120A should readily meet the requirements for an IP-2 package. Nevertheless, this report examines each regulatory requirement individually to assess the package's conformance to IP-2 specifications. However, where appropriate, references are made to the Safety Analysis Report for the CNS 8-120A (Reference 5.2) that was originally prepared to support certification by the NRC. Since the requirements for an IP-2 packaging are more stringent than for an IP-1, this report will serve as a basis for use of the cask as an IP-1 packaging as well.

This Engineering Report evaluates the shipment of solid or liquid radioactive material in this cask when used as an IP-2 or an IP-1 packaging. Although the Safety Analysis Report omits or precludes the shipment of liquids, this exclusion was based on NRC Type A Package requirements; rather than on any design limitations of the cask. The analysis that follows considers the contents to be in liquid or solid state.

The shipper is also responsible for ensuring that the contents do not exceed any of the limits placed on the contents by the analyses in this report.

The applicable requirements for IP-2 packagings is given in 49CFR173.411(b)(2), which is as follows:

Each IP-2 must meet the general design requirements prescribed in §173.410 and when subjected to the tests specified in §173.465 (c) and (d) or evaluated against these tests by any of the methods authorized by §173.461(a), must prevent: (i) Loss or dispersal of the radioactive contents; and (ii) A significant increase in the radiation levels recorded or calculated at the external surfaces for the condition before the test.

Therefore, in addition to §178.350, the requirements for IP-2 packagings are given in the following sections of §173:

Subpart A: General
Subpart B: Preparation of Hazardous Materials for Transportation
173.403: Definitions
173.410: General Design Requirements
173.465: Type A Packaging Tests

The CNS 8-120A is assessed in Section 3.0 below of this report against each of the above requirements. (The requirements of §173.403 are not evaluated, since it contains only definitions rather than specifications.) The methods for demonstrating compliance with the test requirements of §173.465 are given in §173.461. These are; (1) performance of tests, (2) reference to a previous, satisfactory, demonstration of compliance, (3) performance of tests with models, or (4) calculations or reasoned evaluation. The primary method used in this report is method number 4, or reference to the cask SAR which also primarily uses method 4.

This report evaluates the CNS 8-120A for meeting applicable IP-2 requirements. By meeting IP-2 requirements, the package will also meet the requirements for an IP-1 package.

3.0 Results

49CFR173, Subpart A: General

Subpart A does not include any prescriptive specifications for the package.

Part 173 Subpart B: Preparation of Hazardous Materials for Transportation

173.21 Forbidden materials and packages.

This section contains specifications that are either not applicable to the 8-120A, or that must be met by the shipper relative to contents of a shipment.

173.22 Shipper's responsibility.

This section contains specifications that must be met by the shipper.

173.22a Use of packagings authorized under exemptions.

This section is not applicable to the CNS 8-120A.

173.23 Previously authorized packaging.

This section is not applicable to the CNS 8-120A.

173.24 General requirements for packagings and packages.

(a) Applicability. Except as otherwise provided in this subchapter, the provisions of this section apply to-

- (1) Bulk and non-bulk packagings;*
- (2) New packagings and packagings which are reused; and*
- (3) Specification and non-specification packagings.*

The CNS 8-120A is classified as a bulk packaging, therefore this section is applicable.

(b) Each package used for the shipment of hazardous materials under this subchapter shall be designed, constructed, maintained, filled, its contents so limited, and closed, so that under conditions normally incident to transportation-

- (1) Except as otherwise provided in this subchapter, there will be no identifiable (without the use of instruments) release of hazardous materials to the environment;*
- (2) The effectiveness of the package will not be substantially reduced; for example, impact resistance, strength, packaging compatibility, etc. must be maintained for the minimum and maximum temperatures, changes in humidity and pressure, and shocks, loadings and vibrations, normally encountered during transportation;*
- (3) There will be no mixture of gases or vapors in the package which could, through any credible spontaneous increase of heat or pressure, significantly reduce the effectiveness of the packaging.*
- (4) There will be no hazardous material residue adhering to the outside of the package during transport.*

This specification is demonstrated to be met by the CNS 8-120A SAR as discussed under the requirements of §173.465. In addition, prior to transport, the exterior of the package is checked to assure that all radiation and surface contamination levels are within the limits of applicable regulations.

(c) Authorized packagings. A packaging is authorized for a hazardous material only if-

- (1) The packaging is prescribed or permitted for the hazardous material in a packaging section specified for that material in Column 8 of the §172.101 Table and conforms to applicable requirements in the special provisions of Column 7 of the §172.101 Table and, for specification packagings (but not including UN standard packagings manufactured outside the United States), the specification requirements in parts 178 and 179 of this subchapter; or*
- (2) The packaging is permitted under, and conforms to, provisions contained in "Subparts B or C of part 171 of this subchapter or §§ 173.3, 173.4, 173.4a, 173.27, or § 176.11 of this subchapter.*

Column 8 of the §172.101 Table specifies the applicable packaging specifications and exceptions for a hazardous materials being addressed (for example, Radioactive Material, LSA, n.o.s.).

(d) Specification packagings and UN standard packagings manufactured outside the U.S.

173.24(d) specifies requirements of packaging manufactured outside the US. 8-120A is manufactured inside the US, 173.24(d) does not apply.

(e) Compatibility.

(1) Even though certain packagings are specified in this part, it is, nevertheless, the responsibility of the person offering a hazardous material for transportation to ensure that such packagings are compatible with their lading. This particularly applies to corrosivity, permeability, softening, premature aging and embrittlement.

(2) Packaging materials and contents must be such that there will be no significant chemical or galvanic reaction between the materials and contents of the package.

(3) Plastic packagings and receptacles.

(i) Plastic used in packagings and receptacles must be of a type compatible with the lading and may not be permeable to an extent that a hazardous condition is likely to occur during transportation, handling or refilling.

(ii) Each plastic packaging or receptacle which is used for liquid hazardous materials must be capable of withstanding without failure the procedure specified in appendix B of this part ("Procedure for Testing Chemical Compatibility and Rate of Permeation in Plastic Packagings and Receptacles"). The procedure specified in appendix B of this part must be performed on each plastic packaging or receptacle used for Packing Group I materials. The maximum rate of permeation of hazardous lading through or into the plastic packaging or receptacles may not exceed 0.5 percent for materials meeting the definition of a Division 6.1 material according to §173.132 and 2.0 percent for other hazardous materials, when subjected to a temperature no lower than-

(A) 18 °C (64 °F) for 180 days in accordance with Test Method 1 in appendix B of this part;

(B) 50 °C (122 °F) for 28 days in accordance with Test Method 2 in appendix B of this part; or

(C) 60 °C (140 °F) for 14 days in accordance with Test Method 3 in appendix B of this part.

(iii) Alternative procedures or rates of permeation are permitted if they yield a level of safety equivalent to or greater than that provided by paragraph (e)(3)(ii) of this section and are specifically approved by the Associate Administrator.

(4) Mixed contents. Hazardous materials may not be packed or mixed together in the same outer packaging with other hazardous or nonhazardous materials if such materials are capable of reacting dangerously with each other and causing-

(i) Combustion or dangerous evolution of heat;

(ii) Evolution of flammable, poisonous, or asphyxiant gases; or

(iii) Formation of unstable or corrosive materials.

(5) Packagings used for solids, which may become liquid at temperatures likely to be encountered during transportation, must be capable of containing the hazardous material in the liquid state.

This section contains specifications that must be met by the shipper.

173.24(f) Closures.

(1) Closures on packagings shall be so designed and closed that under conditions (including the effects of temperature, pressure and vibration) normally incident to transportation-

(i) Except as provided in paragraph (g) of this section, there is no identifiable release of hazardous materials to the environment from the opening to which the closure is applied; and

(ii) The closure is secure and leakproof and secured against loosening. For air transport, stoppers, corks or other such friction closures must be held in place by positive means.

Compliance to subparagraph (1) is demonstrated by performance of an annual cask inspection, as well as a periodic inspection, for any condition, which would prevent formation of a seal between the sealing surface and the gasket. Furthermore, prior to each shipment, a gasket and seal surface inspection is performed in accordance with the cask's operating procedure.

(2) Except as otherwise provided in this subchapter, a closure (including gaskets or other closure components, if any) used on a specification packaging must conform to all applicable requirements of the specification and must be closed in accordance with information, as applicable, provided by the manufacturer's notification required by §178.2 of this subchapter.

As discussed in the SAR under the requirements of §173.412 and 173.465, the package meets the requirements of this section.

(g) Venting. Venting of packagings, to reduce internal pressure which may develop by the evolution of gas from the contents, is permitted only when-

(1) Except for shipments of cryogenic liquids as specified in §173.320(c) and of carbon dioxide, solid (dry ice), transportation by aircraft is not involved;

(2) Except as otherwise provided in this subchapter, the evolved gases are not poisonous, likely to create a flammable mixture with air or be an asphyxiant under normal conditions of transportation;

(3) The packaging is designed so as to preclude an unintentional release of hazardous materials from the receptacle.

(4) For bulk packagings other than IBCs, venting is authorized for the specific hazardous material by a special provision in the §172.101 Table or by the applicable bulk packaging specification in part 178 of this subchapter.

Not applicable.

(h) Outage and filling limits

(1) General. When filling packagings and receptacles for liquids, sufficient ullage (outage) must be left to ensure that neither leakage nor permanent distortion of the packaging or receptacle will occur as a result of an expansion of the liquid caused by temperatures likely to be encountered during transportation. Requirements for outage and filling limits for non-bulk and bulk packagings are specified in §§173.24a(d) and 173.24b(a), respectively.

(2) Compressed gases and cryogenic liquids. Filling limits for compressed gases and cryogenic liquids are specified in §§173.301 through 173.306 for cylinders and §§173.314 through 173.319 for bulk packagings.

(i) Not applicable, 8-120A not transported by air.

Refer to the discussions in §173.24(b).

173.24a Additional general requirements for non-bulk packagings and packages.

Not applicable; the CNS 8-120A is classified as a bulk packaging.

173.24b Additional general requirements for bulk packagings.

This section contains specifications that must be met by the shipper.

173.25 Authorized packages and overpacks.

Not applicable; this section addresses specifications for overpacks and the package is not classified as an overpack.

173.26 Quantity limitations.

When quantity limitations do not appear in the packaging requirements of this subchapter, the permitted gross weight or capacity authorized for a packaging is as shown in the packaging specification or standard in part 178 or 179, as applicable, of this subchapter.

The permitted capacity and gross weight is given in Chapter 2 of the SAR and marked on the package nameplate.

173.27 General requirements for transportation by aircraft.

Not applicable; the CNS 8-120A is not designed to be transported by aircraft.

173.28 Reuse, reconditioning and remanufacture of packagings.

(a) General. Packagings and receptacles used more than once must be in such condition, including closure devices and cushioning materials, that they conform in all respects to the prescribed requirements of this subchapter. Before reuse, each packaging must be inspected and may not be reused unless free from incompatible residue, rupture, or other damage which reduces its structural integrity.

The package is inspected before each reuse.

(b) Reuse of non-bulk packaging. A non-bulk packaging used more than once must conform to the following provisions and limitations:

Not applicable; the package is classified as a bulk package.

173.29 Empty packagings.

This section contains specifications that must be met by the shipper.

173.30 Loading and unloading of transport vehicles.

A person who is subject to the loading and unloading regulations in this subchapter must load or unload hazardous materials into or from a transport vehicle or vessel in conformance with the applicable loading and unloading requirements of parts 174, 175, 176, and 177 of this subchapter.

This section contains specifications that must be met by the shipper.

173.31 Use of tank cars.

Not applicable.

173.32 Requirements for the use of portable tanks.

Not applicable.

173.33 Hazardous materials in cargo tank motor vehicles.

Not applicable.

173.34 [Reserved]

Not applicable.

173.35 Hazardous materials in intermediate bulk containers.

Not applicable.

173.40 General packaging requirements for toxic materials packaged in cylinders.

Not applicable.

173.410: General design requirements.

In addition to the requirements of subparts A and B of this part, each package used for the shipment of Class 7 (radioactive) materials must be designed so that-

(a) The package can be easily handled and properly secured in or on a conveyance during transport.

The cask is equipped with lifting attachments for handling. It is tied down to the trailer deck during transport. The tiedown system is evaluated structurally in Section 2.4.4 of the Safety Analysis Report (SAR).

(b) Each lifting attachment that is a structural part of the package must be designed with a minimum safety factor of three against yielding when used to lift the package in the intended manner, and it must be designed so that failure of any lifting attachment under excessive load would not impair the ability of the package to meet other requirements of this subpart. Any other structural part of the package which could be used to lift the

package must be capable of being rendered inoperable for lifting the package during transport or must be designed with strength equivalent to that required for lifting attachments.

Section 2.4.3 of the SAR demonstrates that the structural requirements of the lifting attachments are met. Failure of the lifting attachment will not impair the ability of the package to meet other requirements of this subpart. There are no other structural parts of the package that could be used to lift it.

(c) The external surface, as far as practicable, will be free from protruding features and will be easily decontaminated.

The external surfaces of the package are free of protruding features, except those necessary for the package to perform its function. The external surfaces are hard and smooth and therefore easily decontaminated.

(d) The outer layer of packaging will avoid, as far as practicable, pockets or crevices where water might collect.

There are no pockets or crevices on the outer layer of the packaging where water might collect.

(e) Each feature that is added to the package will not reduce the safety of the package.

Features of the package are evaluated in the SAR, and it was determined that there are none that reduce its safety.

(f) The package will be capable of withstanding the effects of any acceleration, vibration or vibration resonance that may arise under normal conditions of transport without any deterioration in the effectiveness of the closing devices on the various receptacles or in the integrity of the package as a whole and without loosening or unintentionally releasing the nuts, bolts, or other securing devices even after repeated use (see §§173.24, 173.24a, and 173.24b).

The package is similar to many other proven casks with many years of operational use in a transport environment. This experience demonstrates that vibrations normally incident to transport will have no effect upon the package.

(g) The materials of construction of the packaging and any components or structure will be physically and chemically compatible with each other and with the package contents. The behavior of the packaging and the package contents under irradiation will be taken into account.

The package is constructed of structural steel and the exterior is primed and painted. As discussed in 2.4.1 of the SAR, there will be no reactions between the package and contents or between the package components.

(h) All valves through which the package contents could escape will be protected against unauthorized operation;

There are no valves in the package.

(i) For transport by air-

Not Applicable, 8-120A is not transported by air.

173.411(a), (b), and (c) industrial packagings

(a) General. Each industrial packaging must comply with the requirements of this section which specifies packaging tests, and record retention applicable to Industrial Packaging Type 1 (IP-1), Industrial Packaging Type 2 (IP-2), and Industrial Packaging Type 3 (IP-3).

The CNS 8-120A Cask complies with the requirements for an Industrial Packaging Type 1 or Type 2 packaging.

(b) Industrial packaging certification and tests.

(1) Each IP-1 must meet the general design requirements prescribed in §173.410.

See (2) below.

(2) Each IP-2 must meet the general design requirements prescribed in §173.410 and when subjected to the tests specified in §173.465 (c) and (d) or evaluated against these tests by any of the methods authorized by §173.461(a), must prevent:

(i) Loss or dispersal of the radioactive contents; and

(ii) A significant increase in the radiation levels recorded or calculated at the external surfaces for the condition before the test.

Compliance was demonstrated in the sections above covering §173.410. As discussed below under §173.465 (c) and (d), the package is evaluated and shown to meet these requirements in the SAR.

(3) Each IP-3 packaging must meet the requirements for an IP-1 and an IP-2, and must meet the requirements specified in §173.412(a) through (j).

Not Applicable.

(4) Each specification IM 101 or IM 102 portable tank (§§178.270, 178.271, 178.272 of this subchapter) that is certified as meeting the requirements for an IP-2 or IP-3 must:

Sections (i) through (iv) not applicable to the 8-120A cask.

(5) Tanks, other than tank containers, including DOT Specification IM 101 or IM 102 steel portable tanks, may be used as Industrial package Type 2 or 3 for transporting LSA-I and LSA-II liquids and gasses as prescribed in Table 6, provided that they conform to standards at least equivalent to those prescribed in paragraph (b)(4) of this section.

Not applicable, CNS 8-120A Cask does not ship liquid or gasses.

(6) Each freight container that is certified as meeting the requirements of IP-2 or IP-3, must-

Sections (i) through (iii) not applicable, CNS 8-120A Cask is not a freight container.

Not Applicable.

(c) Except for IP-1 packagings, each offeror of an industrial package must maintain on file for at least one year after the latest shipment, and shall provide to the Associate Administrator on request, complete documentation of tests and an engineering evaluation or comparative data showing that the construction methods, packaging design, and materials of construction comply with that specification.

This report and the cask's SAR should be retained by the shipper to meet the requirements of this paragraph.

173.465 (c) and (d) Type A packaging tests.

(c) Free drop test. The specimen must drop onto the target so as to suffer maximum damage to the safety features being tested, and:

(1) The height of the drop measured from the lowest point of the specimen to the upper surface of the target may not be less than the distance specified in Table 10, for the applicable package mass. The target must be as specified in §173.465(c)(5). Table 10 is as follows:

<i>Packaging mass Kilograms (pounds)</i>	<i>Free drop distance</i>	
	<i>Meters</i>	<i>Feet</i>
<i><Mass 5000 (11,000)</i>	<i>1.2</i>	<i>4</i>
<i>5,000 (11,000) Mass to 10,000(22,000)</i>	<i>0.9</i>	<i>3</i>
<i>10,000 (22,000) Mass to 15,000(33,000)</i>	<i>0.6</i>	<i>2</i>
<i>>15,000 (33,000) Mass</i>	<i>0.3</i>	<i>1</i>

Sections 2.6.6 and 2.6.7 of the SAR examines the package for the one foot free drop and corner drop. The analyses show that the package can successfully withstand and maintain package integrity for the specified one foot drop.

(2) For packages containing fissile material, the free drop test specified in paragraph (c)(1) of this section must be preceded by a free drop from a height of 0.3 meter (1 foot) on each corner, or in the case of cylindrical packages, onto each of the quarters of each rim.

Not applicable for the CNS 8-120A package.

(3) For fiberboard or wood rectangular packages with a mass of 50 kilograms (110 pounds) or less, a separate specimen must be subjected to a free drop onto each corner from a height of 0.3 meter (1 foot).

Not applicable for the CNS 8-120A package.

(4) For cylindrical fiberboard packages with a mass of 100 kilograms (220 pounds) or less, a separate specimen must be subjected to a free drop onto each of the quarters of each rim from a height of 0.3 meter (1 foot).

Not applicable for the CNS 8-120A package.

(5) The target for the free drop test must be a flat, horizontal surface of such mass and rigidity that any increase in its resistance to displacement or deformation upon impact by the specimen would not significantly increase the damage to the specimen.

The analyses performed was for a drop onto an essentially unyielding surface.

(d) Stacking test.

(1) The specimen must be subjected for a period of at least 24 hours to a compressive load equivalent to the greater of the following:

(i) Five times the mass of the actual package; or

(ii) The equivalent of 13 kilopascals (1.9 pounds per square inch) multiplied by the vertically projected area of the package.

(2) The compressive load must be applied uniformly to two opposite sides of the specimen, one of which must be the base on which the package would normally rest.

Max Package Mass - 74,000 lbs, Diameter of cask - 74.5 inches

Inner shell of cask 1/2 inch thick, 62.5 inches diameter (31.25" radius), Mat'l - ASTM A516-Gr. 60 (yield = 32,000 psi)

§ 173.465 (d)(i) $74,000 \text{ lb} \times 5 = 370,000 \text{ lbs}$

§ 173.465 (d)(ii) $1.9 \text{ psi} \times \left(\frac{\pi \times 74.5^2}{4} \right) = 8,283 \text{ lbs}$

Evaluate package using most severe loading condition, (i).

To evaluate cask for buckling under 5X package load, the cask is modeled as thin-walled circular tube under uniform longitudinal compression, *Roaks's Formulas for Stress and Strain*, Young W., Budynas R. 7th Ed. (Table 15.2, case 15)

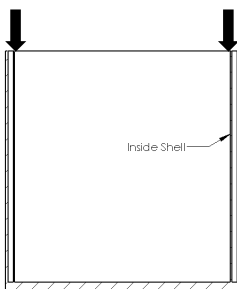

Conservatively only evaluate 1/2 inch thick inside shell of cask.

For validity of formula, $\frac{r}{t} > 10$, $\frac{31.25}{0.5} \gg 10$

where 'r' is radius and 't' is thickness of shell, reference formula valid.

Determining critical buckling stress (σ_{cr}) using case 15.

$$\sigma_{cr} = 0.3 \times \frac{E \times t}{r}$$

where 'E' is modulus of elasticity in pounds per square inch (psi).

$$\sigma_{cr} = 0.3 \times \frac{(30 \times 10^6) \times 0.5}{31.25} = 144,000 \text{ psi}$$

$\sigma_{cr} \gg \sigma_{yield}$ therefore evaluate using yield strength of material.

Calculate stress induced by 5X loading (σ_{5X})

$$\sigma_{5X} = \frac{370,000 \text{ lbs}}{\left(\frac{\pi \times 63.5^2}{4} - \frac{\pi \times 62.5^2}{4} \right)} = 3,739 \text{ psi}$$

$\sigma_{yield} \gg \sigma_{5X}$ 8-120A cask body will not buckle under 5X loading, meets §173.465 (d)

The 8-120A cask package is supplied and shipped with a dedicated conveyance trailer. As such, the package and trailer are integrated during operations as guided by cask handling procedure. The package is not intended to be stacked one on top of the other, however the package is capable of using an interface which allows for stacking and load distributing to comply to §173.465 (d) as demonstrated above.

4.0 Conclusions and Recommendations

The conclusion of this report is that the CNS 8-120A meets the requirements for an IP-1 and IP-2 package.

5.0 References

- 5.1 Code of Federal Regulations, Title 49, Parts 100 through 185, October 1, 2010.
- 5.2 Safety Analysis Report for Chem-Nuclear Systems Model No. CNS 8-120A, Rev. 6, April, 2011.